

Series 533112 CST combined PRV and cold fill monobloc manifold assembly

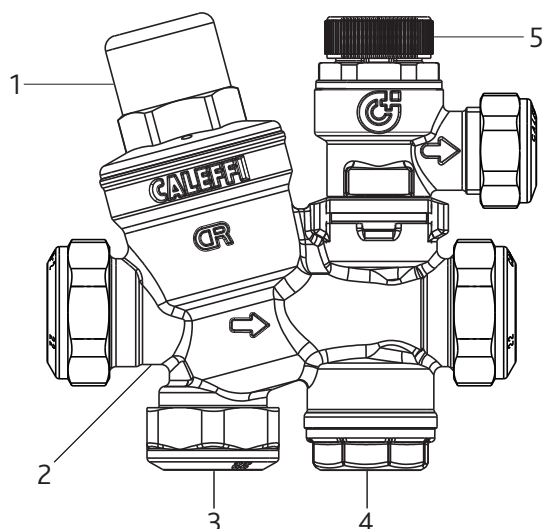

Item	Component
1	Pressure Reducing Valve
2	Manifold Assembly
3	22mm Balanced Take Off
4	Rp $\frac{3}{4}$ Connection for Expansion Vessel
5	Safety Relief Valve

Max. working temperature:	65°C
Max. working pressure:	12 bar
Safety relief valve setting:	6 bar
Pressure reducing valve setting:	3.0 bar

Approvals

WRAS approved product

BS EN 13559: Anti-pollution check valves. DN6 to DN250 inclusive Family E, types A, B, C and D.

BS EN 1491: Building valves. Expansion valves. Expansion valves. Tests and requirements.

BS EN 1567: Building valves. Water pressure reducing valves and combination water reducing valves. Requirements and tests.

Function

Pressure reducing valves (PRV) are installed in domestic water systems to reduce and stabilise the inlet pressure from the mains supply, which is generally too high and variable for domestic appliances to function properly.

Description

The unit comprises of a manifold containing a pressure reducing valve, a cold water balancing port, an expansion vessel connection, a check valve and a preset pressure relief valve.

The unit can be installed either horizontally or vertically with the PRV always first in line.

Installation

Carefully follow these instructions and ensure that the installation conforms to the Water Regulations.

Ensure that sufficient water pressure and flow rate are available.

Open fully all taps before installing the unit to flush the system and expel any air remaining in the pipes.

It is recommended that isolating valves are installed upstream and downstream to facilitate any future maintenance.

Install the unit with the embossed arrow on the manifold pointing in the direction of flow.

The pressure relief valve is free to rotate to the required position.

Ensure that the pressure relief valve discharge pipework has a continuous fall and terminates in such a position as not to cause injury.

Connection (3) on the manifold may be used as a balanced cold water supply. If not used, fit the blanking piece supplied with the unit.

Connection (4) on the manifold is a plugged connection which may be used for direct mounting to an expansion vessel if required. This plug is plastic and has an 'O' ring seal therefore excessive force should not be used for its removal or replacement.

Series 533112 CST combined PRV and cold fill monobloc manifold assembly

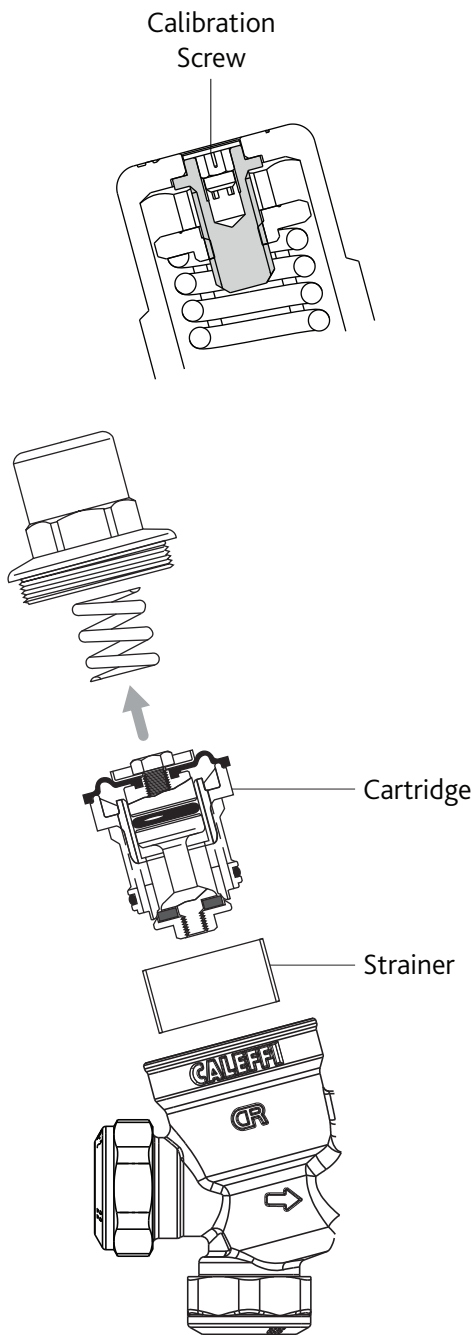

Calibration

Close the downstream isolating valve.

Using an Allen key adjust the outlet pressure by turning the calibration screw in the centre of the plastic cover.

Rotate it clockwise to increase the outlet pressure and anticlockwise to reduce it.

Maintenance and Servicing

Under normal circumstances the unit should not require any maintenance, but regular inspection and cleaning is recommended.

Isolate the water supply to the pressure reducing valve.

Unscrew anticlockwise the central calibration screw to decompress the spring.

Note: Caution should be exercised when disassembling the unit.

Remove the plastic cover using a spanner on the hexagon faces.

Extract the cartridge with the aid of long nosed pliers to grip the head of the set screw.

Remove the strainer element.

Clean the strainer element and cartridge under clean running water.

If the strainer or cartridge are damaged replace.

Refit the strainer, cartridge and cover.

Turn on the water supply and check for leakage.

Re-calibrate the pressure reducing valve.

Typical Installation

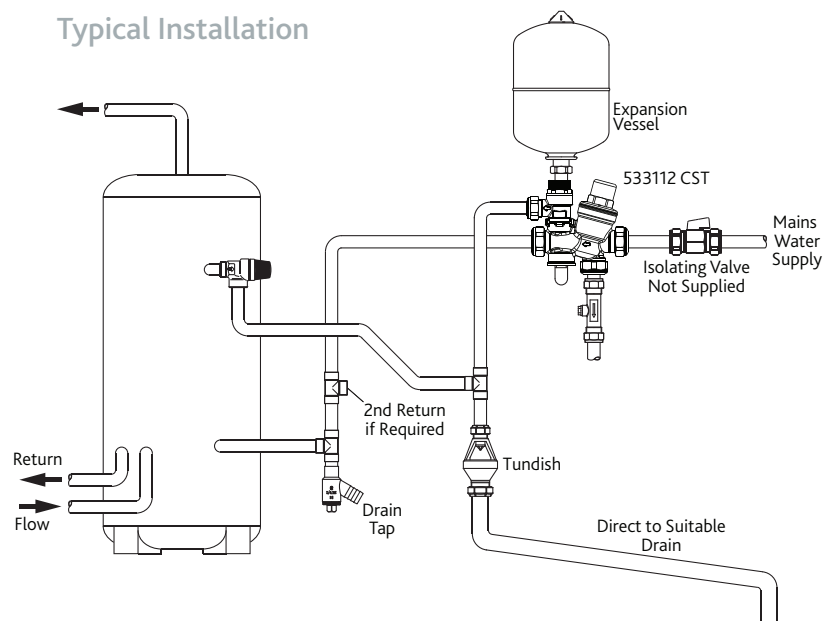

Altecnic Ltd Mustang Drive, Stafford, Staffordshire ST16 1GW

T: +44 (0)1785 218200 E: sales@altecnic.co.uk

Registered in England No: 2095101

altecnic.co.uk

IOM 101 28-10-17

E & O.E

© Altecnic Limited. 2017

ALTECNIC™

altecnic
Caleffi group