

# AI-903/397

double check valve/strainer  
assembly



**altecnic**  
Caleffi group

# AI-903/397 double check valve/strainer assembly



## Application

The AI-903/397 double check valve and Intaball Combi isolating ball valve and strainer are intended for cold water supplies from a public water supply.

The unit is intended to be used where a double check valve is required to prevent backflow and back siphonage contamination in domestic dwellings, public and commercial buildings..

The cold water supply could be to a single domestic boiler, water heater, thermostatic mixing valve, showers, bain taps and toilets.

The two valves are factory assembled saving space and time on site requiring just two joints to be made not four.

Both valves are WRAS approved.

## 397 Intaball Combi Construction Details

Component	Material	Grade
Body	DZR copper alloy	BS EN 12165 CW602N
End connections	DZR copper alloy	BS EN 12165 CW602N
Ball seat	PTFE	
Ball	Brass - chrome plated	BS EN 12165 CW617N
Stem	Brass	BS EN 12164 CW614N
Stem seal	Nitrile	
Strainer screen	Stainless steel	AISI 304

## 397 Technical Data

The maximum pressure and temperature are restricted to that of the double check valve which are lower.

Strainer mesh size:	400 $\mu$ - 0.4 mm
Threaded ends:	BS EN ISO 228 -1
Drain port thread:	G $\frac{1}{4}$

## Dimensions

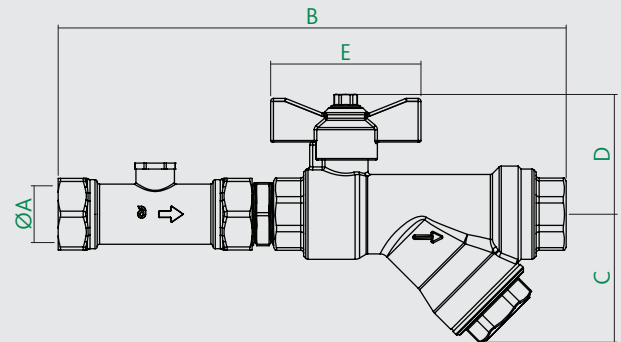

Prod Code	A	B	C	D	E	kg
AI-903/397	G $\frac{1}{2}$	169	42	40	50	

## AI-903 Double Check Valve - Design

Altecnic double check valves comply with BS EN 13959 'Anti-pollution check valves' family E, type D - non controllable.

The Altecnic non verifiable double check valves are manufactured from DZR copper alloy.

The valves provide category 3 protection for both backflow and back siphonage as specified in the Water Supply (Water Fittings) Regulations 1999.

Supplied with an integral test point for monitoring the function of the downstream check valve.

The valves are designed for high flow rates with minimum pressure drops.

## AI-903 Construction Details

Component	Material	Grade
Body	DZR copper alloy	BS EN 12420 CW602N
Cartridge	Plastic	
Cartridge Retaining Clip	Stainless steel	AISI 304
Test Plug	Nylon/Brass	
'O' ring	Nitrile/EPDM rubber	
Compression Nut	Brass	BS EN 12164 CW614N
Olive	Brass	

## AI-903 Technical Data

Max inlet pressure*:	10 bar
Min inlet pressure:	0.2 bar
Max continuous temperature*:	85°C
Conforms to:	BS EN 13959
WRAS approved product	

\* The maximum pressure and temperature of the 397 Intaball Combi are de-rated to that of the double check valve.

## E & O.E

All rights protected under the Copyright, Designs and Patents Act 1988 (as amended). © 2017.

Altecnic Ltd Mustang Drive, Stafford, Staffordshire ST16 1GW

T: +44 (0)1785 218200 E: sales@altecnic.co.uk

Registered in England No: 2095101

altecnic.co.uk

AL279 03-04-17

**altecnic**  
Caleffi group