

5465 Dirtcal®

steel dirt separator



altecnic

5465 Dirtcal® steel dirt separator



Application

In heating and chilled water systems the circulating water will undoubtedly contain debris which entered the pipework during site storage and construction.

The debris may consist of pipe scale, thread turnings, rust particles, thread sealing tape or jointing paste and air borne dust particles.

If left within the pipework this debris may cause erosion to bends and fittings and cause damage to pumps and control valves. Modern systems contain many small control valves in which the seats could become damaged or blocked, these types of valve require a clean system to work efficiently.

Dirt separators are an efficient way of removing debris and are capable of removing small particles down to 5 µm (microns) in size.

Debris is collected in the large chamber allowing longer periods between cleaning, which can be done whilst the system is operating.

Dirt separators if cleaned regularly have a low pressure loss characteristic, important for reducing energy demands and on going running costs.

Design

The Dirtcal® dirt separator is manufactured from epoxy coated steel with a stainless steel internal element.

Suitable for installation in horizontal pipes.

Supplied with PN16 flanges to BS EN 1092 -1.

Low pressure loss.

Supplied with a 1" ball blow down valve.

Top connection threaded ¾" male supplied with blanking plug

Supplied with hot preformed shell for thermal insulation.

Construction Details

Component	Material	Grade
Body	Steel - epoxy coated	
Internal Element	Stainless Steel	BS EN 10088-3
Blowdown Valve	Brass	BS EN 12165 CW617N
Blanking Plug Seal	Non asbestos fibre	
Blanking Plug	Brass	BS EN 12165 CW617N

Product Code	Pipe Orientation	Size	Connections
5465	Horizontal	DN50 to DN150	flanged PN16

Technical Data

Medium:	water glycol solution
Max. percentage of glycol:	50%
Max. working pressure:	10 bar
Temperature range:	0 to 110°C
Minimum particle size:	5 µm

Dimensions

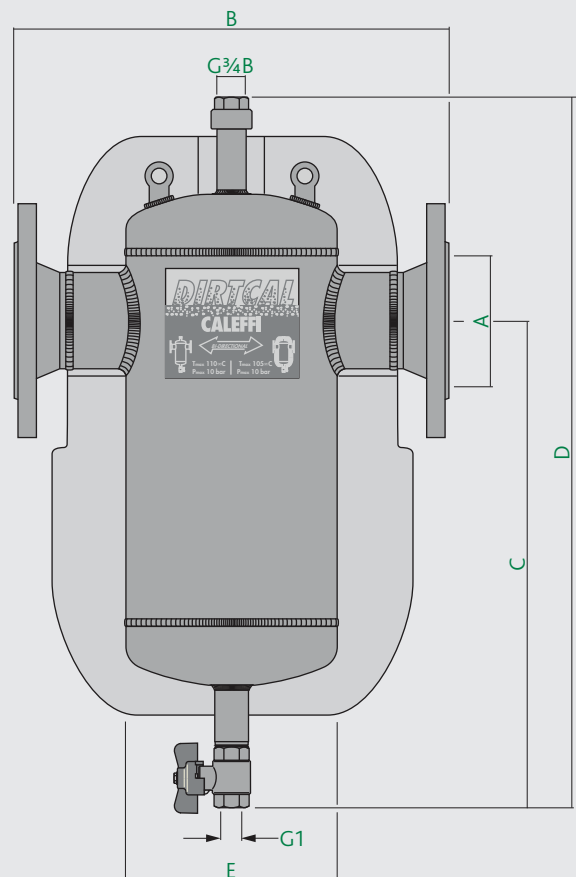

Prod Code	A	B	C	D	E	kg	litre
546550	50	350	425	620	169	13	7
546560	65	350	425	620	169	15	7
546580	80	466	500	740	219	23	18
546510	100	470	500	740	324	25	18
546512	125	635	600	900	324	52	52
546515	150	635	600	900	324	54	52

Operating Principle

Dirt separators operate by a combination of physical principles.

The internal element (1) is constructed to form a radial net shaped element.

Debris in the water strikes the element, causing it to drop to the bottom of the body (2).

The larger internal volume of the Dirtcal®, compared with the area of the pipe, reduces the velocity of flow and with the aid of gravity helps to collect the debris.

The collected debris can be discharge from the dirt separator whilst the system is in operation by opening the blow down valve (3) and flushing through the debris.

The flow can be bi-directional though the Dirtcal®.

5465 Dirtcal[®] steel dirt separator

Operating Principle

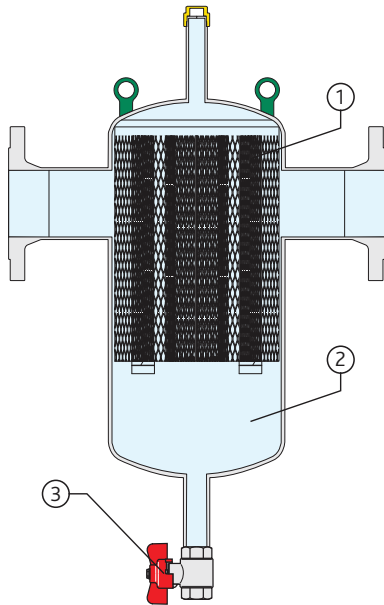

Separation Efficiency

The effectiveness of any device to separate and collect particles of debris from a flowing liquid depends upon:-

- 1 The larger the particles the more effective the device.
- 2 If the flow velocity reduces the particles separate and fall more easily.
- 3 The number of times the liquid re-circulates through the device.

The design of the Dirtcal[®] enables it to collect particles down to a minimum size of 5 µm = 0.005 mm.

The chart summarises tests conducted to illustrate how quickly particles are collected.

After only 50 circulations, approximately one day of operation, 100% of particles 100 µm = 0.1mm in size and approximately 80% of all particles had been collected.

Continued circulation gradually leads to the virtual removal of all particles.

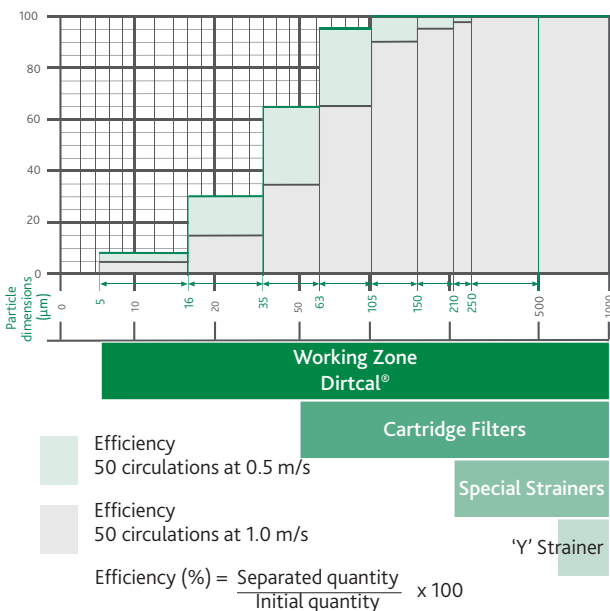

Pressure Loss Chart

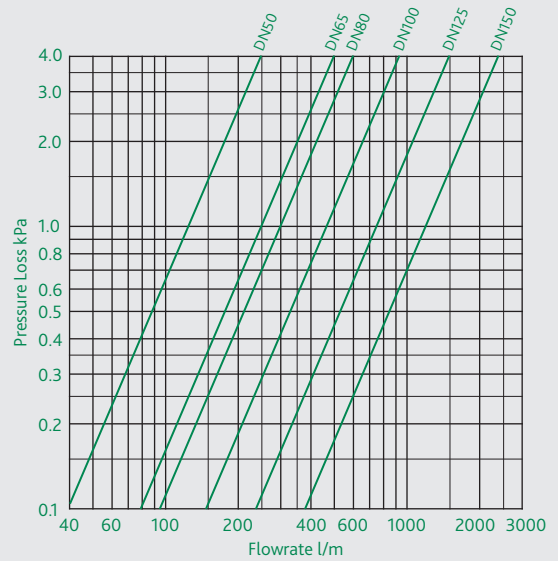

Size - DN	50	65	80	100	125	150
Kv - m ³ /h	75	150	180	280	450	720

The maximum recommended flow velocity inside the pipe is 1.2 m/s. The following shows the maximum flow rates to meet this requirement.

Size - DN	50	65	80	100	125	150
l/m	159	267	369	624	951	1362

Based on BS EN 10255 steel pipe.

Lower Pressure Loss

A conventional 'Y' strainer performs its function via a mesh or perforated sheet element, the size of the holes selected determines the smallest particle size.

The strainer therefore has an initial pressure loss which increases as the basket fills, especially when more than half full.

The dirt separator functions by particles striking the element and dropping into the collection chamber.

The pressure loss is greatly reduced and is not affected by the amount of debris collected.

Note: Both devices require cleaning as part of a planned maintenance programme.

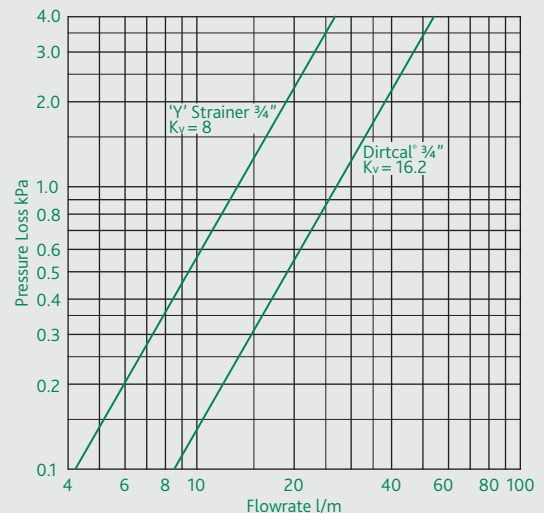

5465 Dirtcal® steel dirt separator

Blowdown Valve

Dirtcal® dirt separators are equipped with a ball isolating blowdown valve.

This valve allows debris in the collection chamber to be flushed through with the system still running, by connecting a suitable pipe or hose and opening the ball valve.

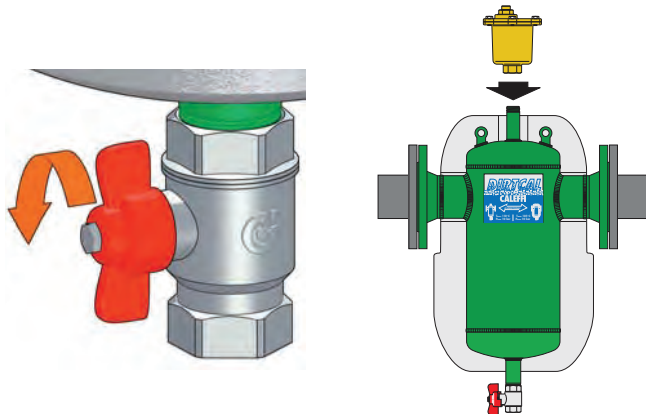

Automatic Air Vent

The threaded connection on top of chamber can be used to install an automatic air vent, the Altecnic Maxcal code 501500.

Installation

Dirt separators are easy to install and should preferably be installed in the return circuit upstream of the boiler.

This enables debris present in the pipework to be intercepted before it reaches the boiler or chiller, particularly during system flushing.

Dirt separators should always be installed as shown with the blowdown valve beneath the collection chamber.

Dirtcal® dirt separators are bi-directional but should only be installed in horizontal pipework.

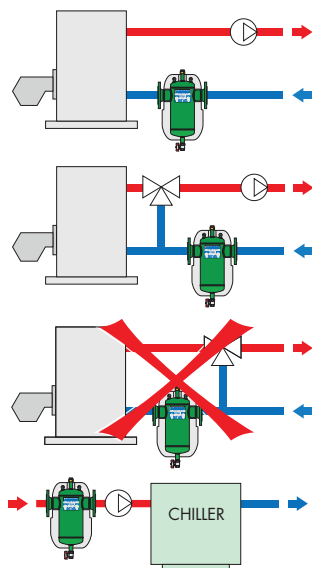

E & O.E

Altecnic Ltd Mustang Drive, Stafford, Staffordshire ST16 1GW

T: +44 (0)1785 218200 E: sales@altecnic.co.

Registered in England No: 2095101

altecnic.co.uk

AL013 24-08-15

Insulation Shell

Flanged Dirtcal® dirt separators are supplied complete with a hot preformed insulation shell.

This ensures not only perfect thermal insulation but also the tightness required to prevent condensation forming on the surface.

For this reason, this type of insulation may be used on chilled water applications.

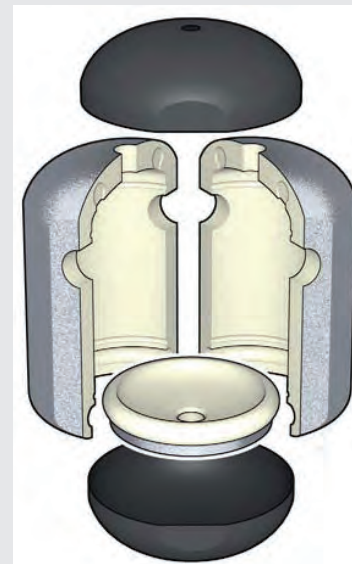

Technical Specification of Insulation Shell

DN50 to DN100 - Insulation

Material:	Rigid closed cell expanded polyurethane form
Thickness:	60mm
Density:	45 kg/m ³
Thermal conductivity (ISO 2581):	0.023 W/(m.K)
Working temperature range:	0 to 105°C

DN50 to DN100 - Head Covers

Heat moulded material:	PS
------------------------	----

DN125 to DN150 - Insulation

Material:	Closed cell expanded PE-X
Thickness:	60mm
Density:	- inner part 30 kg/m ³ - outer part 80 kg/m ³
Thermal conductivity (ISO 2581):	at 0°C 0.038W/(m.K) at 40°C 0.045W/(m.K)
Coefficient of resistance to water vapour (DIN 52615):	> 1.300
Working temperature range:	0 to 100°C
Resistance to fire (DIN 4102):	class B2

External Layer - all sizes

Material:	embossed unfinished aluminium
Thickness:	0.7mm
Resistance to fire (DIN 4102)	class 1