

# 28mm mixcal III group

thermostatic mixing valve



**altecnic**  
CALEFFI group

# 28mm mixcal III group thermostatic mixing valve



## Application

Thermostatic mixing valves are used to maintain the domestic hot water supplied to the user at a constant and safe temperature, when variations in the hot and cold water supply conditions and draw off flow rates occur.

The mixcal III group thermostatic mixing valve has been designed especially for centralised systems which demand high flow rates, for example with multiple outlets such as shower and wash basins.

## Operating Principle

The controlling element of the mixing valve is a temperature sensor fully immersed in the mixed water outlet port, which expands or contracts, continually maintaining the correct proportion of hot and cold water entering the valve.

Even when the supply pressures drop, due to draw off of hot and cold water by other users on the same system, or variations in the incoming water temperatures, the mixing valve automatically responds and maintains the mixed outlet water at the required temperature.

## Connections

The valve is supplied complete with union tails which incorporate compression connections and those to the hot and cold water supplies have an integral single check valve and filter to prevent debris from entering the valve.

## Construction Details

Component	Material	Grade
Body	DZR - chrome plated	BS EN 1982 CB752S
Shutter	Polymer	PPS G40
Springs	Stainless steel	
Seals	EPDM	

Product Code	Size	Connection	Type
521928	28 mm	compression	Cu x Cu x Cu

## Dimensions

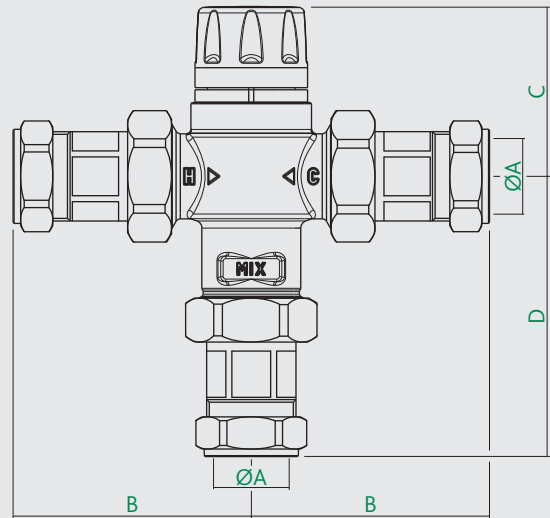

Prod Code	A	B	C	D	kg
521928	Ø28	95	68	113	

## Technical Data

Max. working pressure:	14 bar - Static 5 bar - Dynamic
Max. inlet temperature:	90°C
Max. inlet pressure ratio (H/C or C/H):	2:1
Accuracy:	±2°C
Setting Range:	35 to 65°C
Compression ends:	BS EN 1254-2
Kv	3.0 m³/h
WRAS approved product	

© Patents & Design Altecnic 2020

Altecnic Ltd retains all rights (including patents, designs and copyrights, trademarks and any other intellectual property rights) in relation to all information provided on or via the website, brochures or any other documents, including all texts, graphics and logos, contained on the website, in brochures or in any other documents published in the name of or on behalf of Altecnic Ltd in any form, without prior written consent of Altecnic Ltd.

Altecnic Ltd Mustang Drive, Stafford, Staffordshire ST16 1GW

T: +44 (0)1785 218200 E: sales@altecnic.co.uk

Registered in England No: 2095101

altecnic.co.uk

AL 138 10-01-20

E & O.E

© Altecnic Limited. 2020

ALTECNIC™

**altecnic**  
CALEFFI group