



ART 5213 & 5219

OEM thermostatic mixing valve

SD 008 07-05-2020

Application

Thermostatic mixing valves are used to maintain the domestic hot water supplied to the user at a constant and safe temperature, when variations in the hot and cold water supply conditions and draw off flow rates occur.

The Art 5213 and Art 5219 thermostatic mixing valves are designed primarily for single outlet use.

The valves are fail safe thermostatic mixing valves and provide a high volume of hot water at a stable temperature.

They delivers mixed hot water at a set temperature to taps, showers, baths and bidets making it ideal for use in domestic and commercial hot water systems.

Operating Principle

The controlling element of the mixing valve is a temperature sensor fully immersed in the mixed water outlet port, which expands or contracts, continually maintaining the correct proportion of hot and cold water entering the valve.

Even when the supply pressures drop, due to draw off of hot and cold water by other users on the same system, or variations in the incoming water temperatures, the mixing valve automatically responds and maintains the mixed outlet water at the required temperature.

Design

The valve has clean lines and is easy to clean, helping to improve and maintain hygiene standards.

The robust construction makes it suitable for exposed installation in public wash rooms and other commercial applications.

BS EN 1287 and TMV2

The valves have been specifically designed and manufactured to meet the requirements of BS EN 1287: 2017 and TMV2 Type Scheme. The valves have been independently tested and approved as a TYPE 2 valve under the NSF TMV2 scheme by the NSF Testing and Evaluation Centre for low pressure applications.

Construction Details

Component	Material	Grade
Body	Brass - chrome plated	BS EN 12165 CW617N
Internal components	Brass	BS EN 12164 CW614N
Seals	EPDM	
Setting knob	Nylon	
Compression screw	Brass - chrome plated	BS EN 12164 CW614N
Olive	Brass	

Ref No	Size	Connection	Type
521331 CST	G½/15 mm	compression	pre-set at 61°C
521332 CST	G½/15 mm	compression	pre-set at 51°C
521931 CST	G½/15 mm	compression	adjustable 35 to 65°C

Dimensions

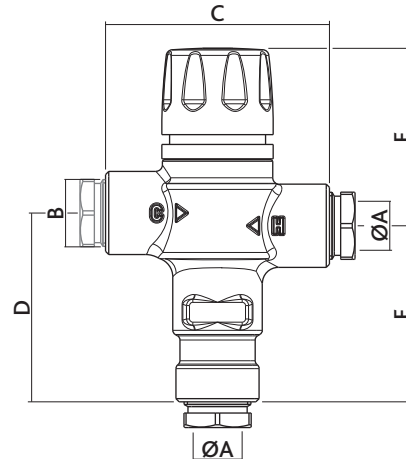

Ref No	ØA	B	C	D	E	F	kg
521331 CST	15	G½	70	59	55		
521332 CST	15	G½	70	59	55		
521931 CST	15	G½	70	59	55		

Technical Data

Complies with;	BS EN 1287:2017
Max. working pressure:	10 bar - Static
Max. inlet temperature:	85°C
Max. inlet pressure ratio (H/C or C/H):	2:1
Accuracy:	±2°C
Setting Range:	30 to 65°C
Min. temperature difference between inlet hot water and outlet mixed water:	15°C
Min. flow rate for stable temperature:	5 l/m
Compression ends:	BS EN 1254-2
Threaded ends:	BS EN ISO 228/1

Hydraulic Characteristics & Kv Value

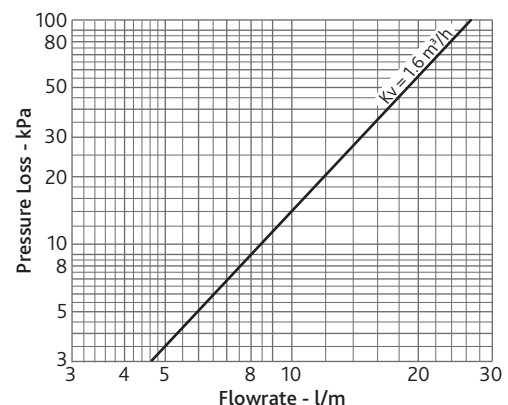

© Patents & Design Altecnic 2020

Altecnic Ltd retains all rights (including patents, designs and copyrights, trademarks and any other intellectual property rights) in relation to all information provided on or via the website, brochures or any other documents, including all texts, graphics and logos, contained on the website, in brochures or in any other documents published in the name of or on behalf of Altecnic Ltd in any form, without prior written consent of Altecnic Ltd.

Altecnic Ltd Mustang Drive, Stafford, Staffordshire ST16 1GW T: +44 (0)1785 218200 E: sales@altecnic.co.uk altecnic.co.uk

Registered in England No: 2095101 E & O.E © Altecnic Limited. 2020 ALTECNIC™