

263320 & 263350

DTC 55°C to 60°C storage to
boiler thermostatic
connection kit



installation guide

altecnic
Caleffi group

263320 & 50 DTC 55°C to 60°C storage to boiler thermostatic connection kit



Function

A DTC valve is used in systems where the water in the storage cylinder can reach temperatures significantly above 60°C, for example if heated by solar heating.

These particular valves have been certified as being compliant with the requirements of BS EN 15092.

Other precautions need to be taken at the point of use to reduce the water to a safe temperature and prevent scalding.

Product Range

Product Code	Size	Connections
263320	22mm	compression
263350	¾"	m x m screwed iron

Description

The 263320 valve has compression connections, check valves and filters.

The 263350 valve has male connections, check valves and filters.

The 263320 and 263350 have been designated as a Type 1 valve, which is non adjustable and has a preset temperature between 55°C and 60°C.

Construction Details

Component	Material	Grade
Body	DZR Brass	BS EN 1982 CB752S chrome plated
Obturator	PSU	
Spring	Stainless steel	
Seals	EPDM	
Cover	ABS	
Union seals	non asbestos fibre	

Technical Data

Thermostatic mixing valve

Max. working pressure:	10 bar - Static 5 bar - Dynamic
Max. inlet temperature:	100°C
Max. inlet press ratio H/C or C/H):	2:1
Min. temperature difference between inlet hot water and outlet mixed water for best performance:	10°C
Temperature setting range:	55 to 60°C
Factory set temperature:	55°C
BS EN15092 set temperature range:	45 to 65°C
Accuracy:	±2°C
Min. flow rate for stable operation:	4 l/m
Nom. flow rate at 1 bar:	20 l/m

Thermostatic diverter valve

Max. working pressure:	10 bar
Max. differential pressure:	5 bar
Max. inlet temperature:	100°C
Factory set temperature:	55°C
Accuracy:	±2°C

Thermostatic control device

Max. working pressure:	10 bar
Factory set temperature:	55°C
Accuracy:	±2°C

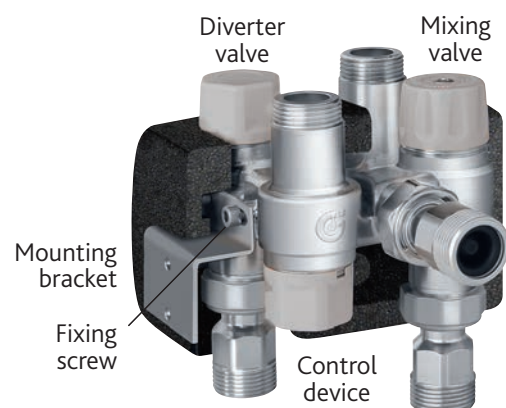

263320 & 50 DTC 55°C to 60°C storage to boiler thermostatic connection kit

Flowrates

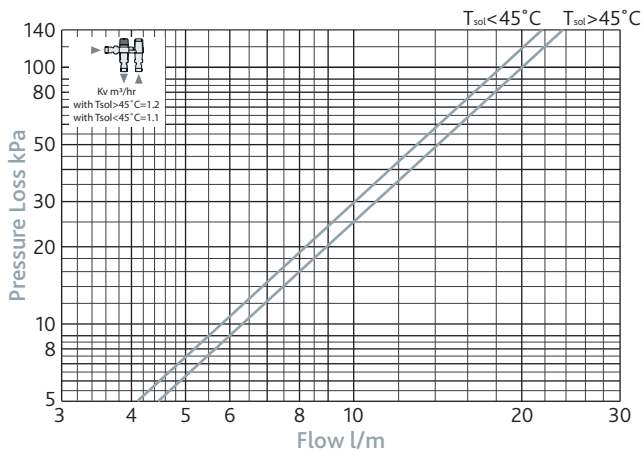

Dimensions

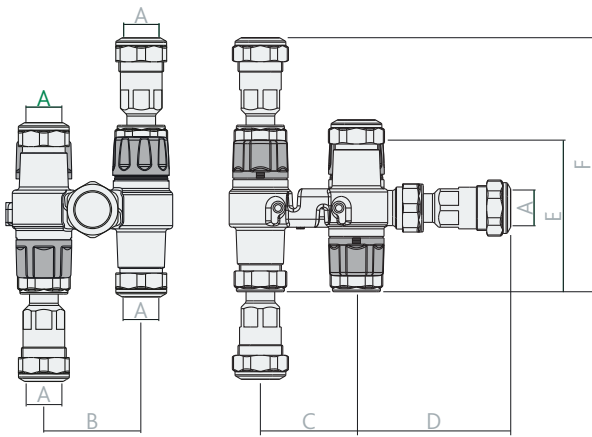

Code	A	B	C	D	E	F	kg
263320	Ø22	60	60	96.5	98	161	1.90

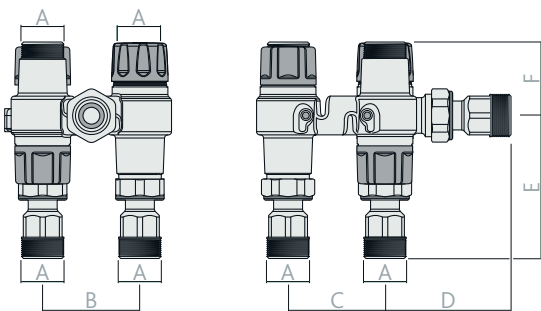

Code	A	B	C	D	E	F	kg
263350	G¾B	60	60	78	88.5	45.5	1.85

Anti Back Siphonage Devices

The 263320 and 263350 have single check valves and filters incorporated into two inlet ports, the cold feed and the inlet from solar storage.

These check valves comply with BS EN 13959.

Any additional check valves installed in conjunction with the 263 must also comply with BS EN 13959.

Thermal Shut-off

In the event of failure of the hot or cold water supply, the piston will shut off, stopping water discharging from the mixed water outlet.

To ensure the correct operation of the thermal shut-off feature, a minimum temperature differential from the hot inlet to the mixed water outlet of 10°C is required.

Conditions of use in accordance with BS EN 15092 and DTC Scheme

Conditions	Limits of use	Recommended limits of operation
Dynamic pressure	0.2 bar min.	1 bar ≤ P ≤ 5 bar
Static pressure	10 bar max.	
Hot water inlet temperature	T ≤ 90°C	60°C ≤ T ≤ 80°C
Cold water inlet temperature	T ≤ 25°C	T ≤ 25°C
Distribution (outlet) temperature	55°C ≤ T ≤ 60°C (DTC Scheme)	
Distribution (outlet) temperature	45°C ≤ T ≤ 65°C (BS EN 15092)	

Note: Valves operating outside these conditions cannot be guaranteed by the Scheme to operate as a DTC approved valves.

Installation

Tempering valves are intended to be used adjacent to the hot water storage heater to provide tempered water to the terminal fittings and are not intended to control the water temperature at point of use.

A tempering valve is not a safety device.

The installation of the 263 valves must comply with the requirements of the Water Supply (Water Fittings) Regulations 1999.

Check the system before installing the 263 valves, to make sure that the operating parameters of the system fall within the functioning range of the mixing valve (for example in terms of supply temperature and pressure, etc.).

The system in which the 263 valves are to be installed must be flushed and cleaned to remove any dirt that may have accumulated during installation.

Failure to remove impurities may affect product performance and invalidate the manufacturer's warranty.

The valve must be installed in an accessible position to allow maintenance of the valve and its supply valves and commissioning and testing to be undertaken.

263320 & 50 DTC 55°C to 60°C storage to boiler thermostatic connection kit

Installation

The 263 is supplied with a mounting bracket which must be used to mount the valve.

The pipes leading into and out of the valve must not be used to support the weight of the valve.

The 263 valves must be installed as per the application diagrams in this manual.

The hot and cold water supplies to the valve must be installed according to the markings on the valve itself.

- The hot water inlet is marked with the letter H.
- The cold water inlet is marked with the letter C.
- The outlet to the boiler is marked 'Outlet Boiler'
- The mixed water outlet is marked 'MIX'.
- The boiler connection is marked 'Inlet Boiler'

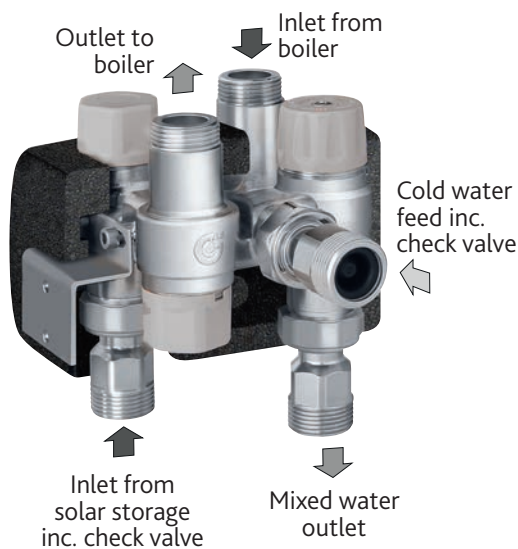

The valve should be installed with isolation valves, strainers and check valves at the water inlets.

Isolation valves are required as close as is practicable to the water supply inlets to enable the valve to be isolated for maintenance.

The filters are recommended as close as is practicable to the water supply inlets as they prevent impurities from entering the tempering valve.

The check valves are required as close as is practicable to the water supply inlets for the prevention of cross-circulation and backflow.

The Distribution Tempering Valve Scheme recommends that the system has suitable test points installed in order that the performance of the tempering valve can be verified.

Application Diagrams

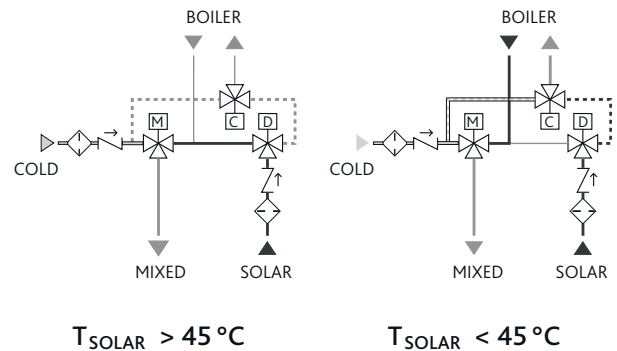

Connections

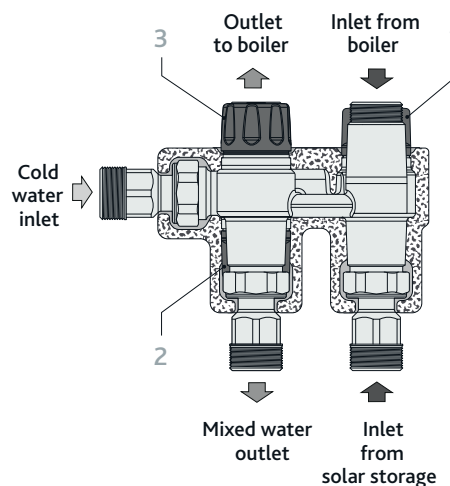

Commissioning

After installation, the mixing valve must be tested and commissioned by an authorised technician in accordance with the procedure given below and as specified by current applicable legislation.

The following instructions must be read and understood before commissioning the 263320 and 263350 valves.

If there are any aspects of the installation or the system which do not correspond to the specified requirements, the valve must not be commissioned until the installation/system is made to conform to the said requirements.

The use of a digital thermometer is recommended and the sensing part of the thermometer probe must be fully submerged in the water being tested.

Commissioning

- 1 Ensure that the supply pressures and temperatures are within the valve's operating range before commencing commissioning.
- 2 Ensure that the system is clean and free from debris, which may have accumulated during installation, before commissioning the tempering valve.
- 3 Set the mixed water temperature, with a calibrated digital thermometer, the sensing part must be fully submerged in the water that is being tested. Measure the temperature of the mixed water flowing from outlet points when commissioning the tempering valve.
- 4 Depending on the intended use and associated risk, the temperature at the outlet must be regulated so it does not present a danger to the user and that it remains within the limits stipulated by established legislation.
- 5 The temperature at the valve outlet must be set while taking into account potential temperature fluctuations caused by the simultaneous demands. It is advisable that any outlets which are connected to the same supply as the tempering valve are opened during the setting of the mixed water temperature. During commissioning it is advisable to ensure that the water temperatures are stabilized before any attempt to commission.
- 6 The temperature may be adjusted using the control knob.
 - a) Adjust the temperature of the mixed water, which must not exceed $60\pm 2^\circ\text{C}$ or be below 55°C to the desired value.
 - b) Measure and record the temperature at the cold and hot water inlets.
 - c) Measure and record the temperature of the water delivered from the tap at the lowest and highest flow rates.
 - d) Carry out the cold water supply isolation test by isolating the cold water supply to the tempering valve, wait for 5 seconds if water is still flowing check that the temperature is not below 55°C or exceeds $60\pm 2^\circ\text{C}$.
 - e) Measure and record the maximum mixed water temperature. The temperature may not exceed the values permitted in any applicable legislation or code of practice.
 - f) If there is residual flow during the cold water supply isolation test, this is acceptable providing the temperature of the water seeping from the valve is no higher than 2°C above the designated maximum mixed water outlet temperature setting of the valve

Commissioning

- g) Restore the cold water inlet supply and measure the water delivery temperature after it has stabilised. The final temperature measured in this test may not exceed the permitted values by $\pm 2^\circ\text{C}$.

All the above information should be recorded in the commissioning report and updated in the maintenance report whenever the valve is worked on.

Any tempering valve that has been adjusted or serviced must be re-commissioned and retested in accordance with these instructions.

Setting the Temperature

The temperature is set to the required value by means of the adjusting knob with the graduated scale located at the top of the valve clearly marked.

Preset Locking

Position the adjusting knob to the number required.

Unscrew the retaining screw.

Remove the knob by pulling away from the valve and reposition on the splined shaft so that the internal slot locates on the position indicator on the knob frame.

Re fit and tighten the retaining screw

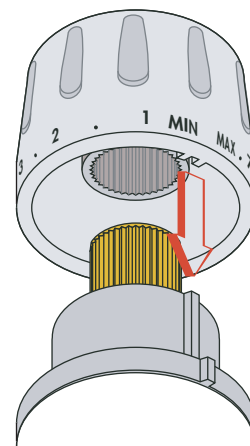

Position	Min	1	2	3	4	5	6	7	Max
T°C	27	32	38	44	49	53	58	63	67

with: $T_{\text{HOT}} = 68^\circ\text{C}$ $T_{\text{COLD}} = 13^\circ\text{C}$ $P = 3 \text{ bar}$

263320 & 50 DTC 55°C to 60°C storage to boiler thermostatic connection kit

Maintenance

In service tests should be carried out regularly to monitor the tempering valve's performance, as deterioration of performance could indicate that the valve and/or the system require maintenance.

If, during these tests, the temperature of the mixed water has changed significantly when compared with the previous test, the details given in the Installation and Commissioning sections should be checked and maintenance carried out.

The following should be checked regularly to ensure that the optimum performance levels of the valve are maintained.

Every 12 months or more often if necessary.

- 1 The hot and cold water inlet filters can be removed for cleaning by unscrewing the union nuts.
- 2 The non return valves can be inspected by unscrewing the union nuts, check that they are operating correctly and free from debris.
- 3 Limescale can be removed from internal components by immersion in a suitable de-scaling fluid. Check the O-rings and lubricate them with a suitable lubricant.
- 4 When the components have been checked and maintained, the valve should be re-commissioned following the specified procedure.

Safety

The 263320 and 263350 valves must be installed by qualified personnel and comply with the requirements of the Water Supply (Water Fittings) Regulations 1999.

If the valve is not installed, commissioned and maintained properly, according to the instructions contained in this manual, it may not operate correctly and may endanger the user.

Make sure that all the connecting pipework is water tight.

When connecting the valve to the pipework ensure the joints are not mechanically over-stressed. Over time this could cause a fracture, with consequential water loss which, in turn, could cause harm to property or people.

Water temperatures higher than 50°C can cause serious scalding.

During installation, commissioning and maintenance take the necessary precautions to ensure that such temperatures do not endanger people.

In the case of highly aggressive water, arrangements must be made to treat the water before it enters the thermostatic mixing valve, in accordance with current legislation. Otherwise, it may become damaged and not operate correctly.

Typical Application Diagram

Natural circulation solar system

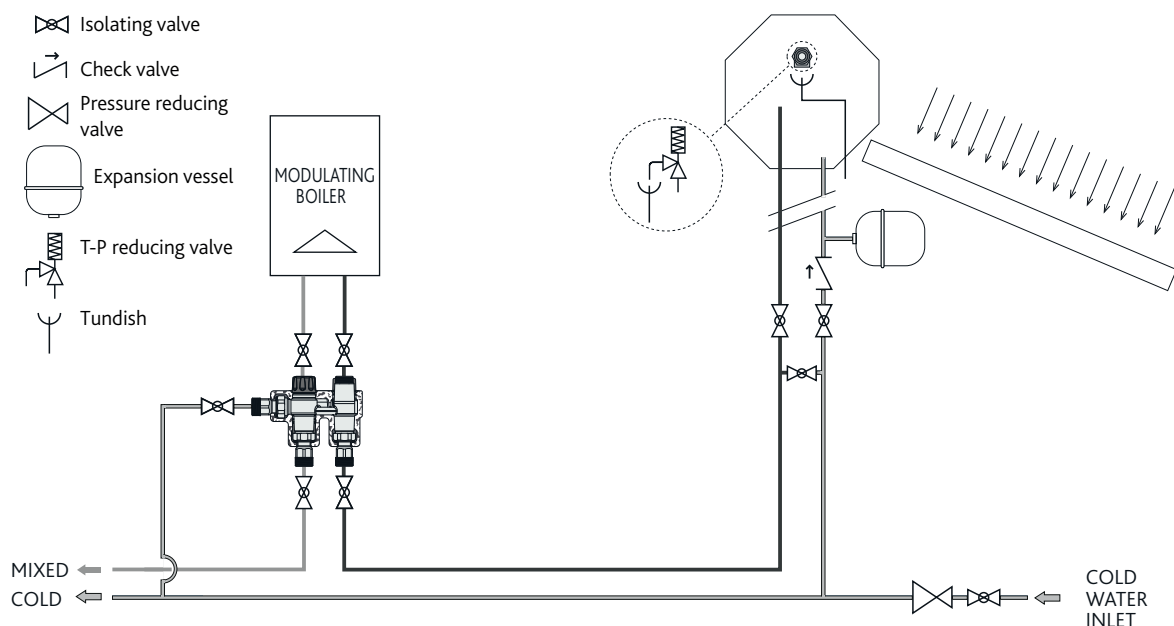

263320 & 50 DTC 55°C to 60°C storage to boiler thermostatic connection kit

Problem Solving

In normal operating conditions the 263320 and 263350 valves should give long and reliable performance.

However, in certain circumstances or if the maintenance schedule is not observed, the following problems may arise.

Symptoms	Cause	Solution
Hot water delivery at cold water tap	Inlet check valves not operating correctly or seals worn/damaged Check valves not fitted	Replace damaged check valve
Fluctuations in temperature of mixed water	Incorrect inlet water temperature Insufficient inlet water flow Commissioning not performed correctly	Restore inlet conditions to within valve specification range
Incorrect outlet flow rate	Insufficient water supply Fluctuations in temperature/pressure at inlet Unfavourable conditions created by the operation of other water outlets	Stabilise water supply to valve
No outlet flow	In-line filters blocked Insufficient supply pressure Debris blocking water flow through valve	Clean filters Restore supply conditions Remove debris/limescale from the valve
Valve anti-scalding feature not performed when tested	Installation not compliant with instructions Minimum temperature difference not reached Valve mechanism blocked by debris	Follow installation instructions Increase hot water temperature Remove debris/limescale from the valve

Please leave this Manual for the User

E & O.E
© Altecnic Ltd. 2017

Altecnic Ltd Mustang Drive, Stafford, Staffordshire ST16 1GW

T: +44 (0)1785 218200 E: sales@altecnic.co.uk

Registered in England No: 2095101

altecnic.co.uk

IOM 017 20-04-17

altecnic
Caleffi group