

145 PICV

pressure independent
control valve



altecnic
CALEFFI group

145 PICV pressure independent control valve



Application

The pressure independent control valve (PICV) is a valve comprising an automatic flow rate regulator and a control valve with actuator.

The valve can adjust the flow rate and keep it constant in the presence of changing differential pressure conditions of the circuit.

Flow rate is adjusted in two different ways:

- manually on the automatic flow rate regulator, to restrict the maximum value
- automatically by the control valve in combination with a proportional (0 to 10 V) or ON/OFF actuator, in accordance with the thermal load requirements of the circuit of the system to be controlled.

The pressure independent control valve (PIVC) is supplied complete with connections for upstream and downstream pressure test ports for checking of operating conditions.

The valve can be used in heating and air-conditioning systems.

Product Range

Product Code	Valve Size	Connection Size	Description
145420	DN15	3/8"	PICV
145430	DN15	3/8"	PICV
145440	DN15	1/2"	PICV
145550	DN20	3/4"	PICV
145660	DN20	1"	PICV
145552	DN20	3/4"	PICV with 24 V Actuator

Technical Specification

Material

Body:	dezincification resistant alloy BS EN 12165 CW602N
Headworks:	dezincification resistant alloy BS EN 12164 CW602N
Control stem & piston:	stainless steel BS EN 10088-3 (AISI 303)
Body seat:	PTFE
Disc facing:	EPDM
Pressure regulating diaphragm:	EPDM
Springs:	stainless steel BS EN 10270-3 (AISI 320)
Seals:	EPDM
Gasket:	non-asbestos fibre
Pre-adjustment indicator:	nylon 6 - PA6G30
Knob:	nylon 6 - PA6

Technical Specification

Performance

Medium:	water, glycol solution
Max. percentage of glycol:	30%
Max. working pressure:	10 bar
Max. differential pressure with code 145014 actuator and 656 series thermo-electric actuators:	5 bar
Working temperature range:	-20 to 120°C
Nominal Δp control range:	0.02 to 0.2 m ³ /h 0.08 to 0.4 m ³ /h 0.08 to 0.8 m ³ /h 0.12 to 1.2 m ³ /h
Accuracy:	±15%
Max. flow rate with 656 series thermo-electric actuator fitted reduced by:	20%

Connections

Main	3/8", 1/2", 3/4" and 1" male BS EN 10226-1 with union 3/4" male BS EN ISO 228-1 Euro-connection
For electro-thermal actuators:	M30 x 1.5
For pressure test ports:	1/4" female BS EN ISO 228-1 with plug

14514 Proportional Linear Actuator

Electrical supply:	24 V ac/dc
Power consumption:	2.5 W ac 1.5 W dc
Control signal:	0-10 V
Protection class:	IP 43
Ambient temperature range:	0 to 50°C
Supply cable length:	1.5m
Connection:	M30 x 1.5

145 PICV pressure independent control valve

Dimensions

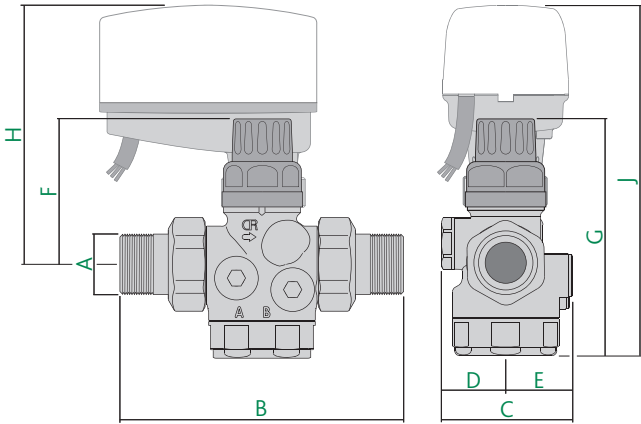

Prod Code	DN	A	B	C	D	E
145420	15	3/8"	108	51	25	26
145430	15	3/8"	108	51	25	26
145440	15	1/2"	110	51	25	26
145550	20	3/4"	123	51	25	26
145560	20	1"	132	51	25	26
145552	20	3/4"*	70#	51	25	26

Prod Code	DN	F	G	H	J	kg
145420	15	55	95	96	132	0.53
145430	15	55	95	96	132	0.53
145440	15	55	95	96	132	0.57
145550	20	55	95	96	132	0.70
145560	20	55	95	96	132	0.70
145552	20	55	95	96	132	0.47

* BS EN ISO 228-1 thread

without male union connections

Operating Principle

The pressure independent control valve (PICV) is designed to regulate a flow of fluid by:

- an actuated 2-port control valve that varies the flow through a terminal unit.
- a differential pressure control regulator that maintains a constant differential pressure across the control valve thereby ensuring the maximum set design flow rate cannot be exceeded.

The valve construction is shown in the schematic diagram.

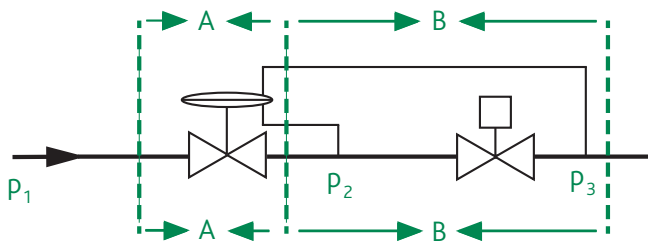

Where:

p_1 = upstream pressure p_3 = downstream pressure
 p_2 = intermediate pressure Δp total valve = $p_1 - p_2$

Operating Principle

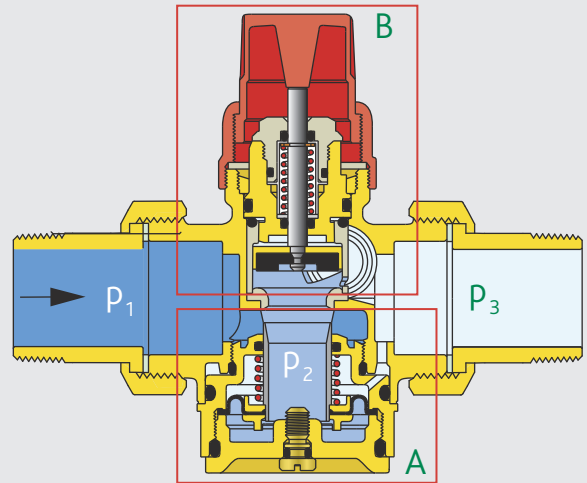

Device **A** regulates Δp_i ($p_2 - p_3$) and keeps it constant across the valve **B** by means of an automatic action (balancing between the force generated by the differential pressure and the internal opposing spring).

If ($p_2 - p_3$) increases, the internal Δp regulator reacts to close the valve and maintains ($p_2 - p_3$) constant.

In these conditions the flow rate will remain constant.

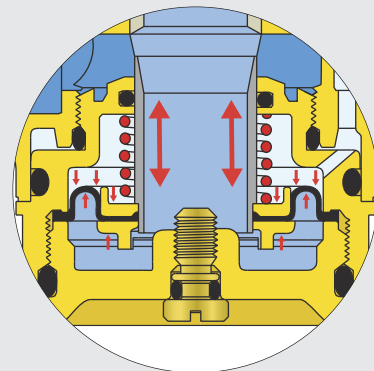

Valve **B** regulates flow rate G by changing the flow path cross section.

The change in flow path cross section determines the hydraulic coefficient value K_v of the regulating valve **B**, which remains constantly at:

- a manually pre-set value
- the value determined by the actuator's regulating action.

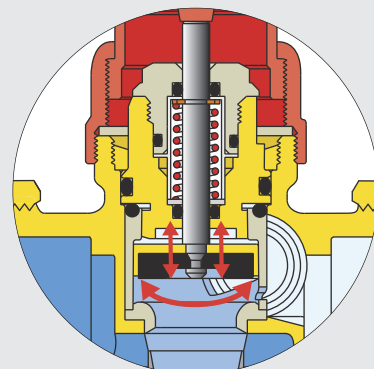

145 PICV pressure independent control valve

Constant Flow Rate

G = required flow rate

Since $G = K_v \times \sqrt{\Delta p}$

- by manually or automatically adjusting valve **B**, the K_v value and consequently the flow rate G can be set.
- once the flow rate G has been set, it remains constant as a result of device **A** in response to circuit pressure changes.

Differential Pressure Range

For the valve to keep the flow rate constant irrespective of changes in the circuit's differential pressure, total valve Δp (p_1-p_3) must be in the range from the minimum Δp value (see "Flow rate adjustment tables") and the maximum value of 400 kPa.

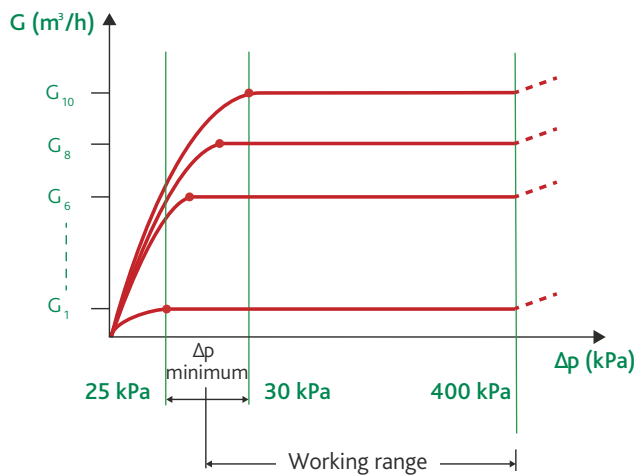

Flow Rate Accuracy

Flow rate accuracy

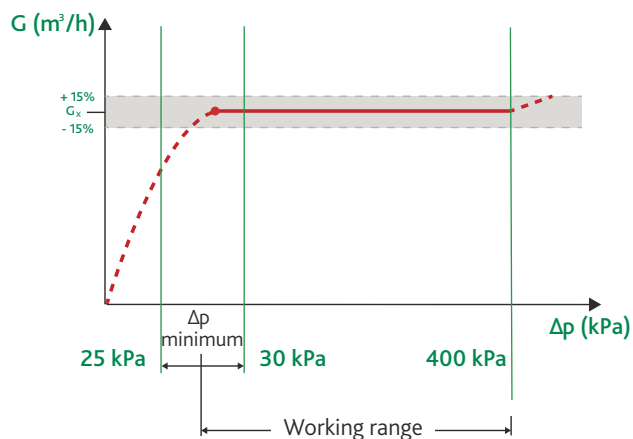

Construction Details

Materials in dezincification resistant alloy and stainless steel

Valve body (1) and headwork (2) are made of dezincification resistant alloy while springs (3), control stem (4) and piston (5) are in stainless steel.

These materials prevent corrosion, guarantee accuracy, reliable performance over time and are compatible with glycols and additives, which are often used in the circuits of air conditioning systems.

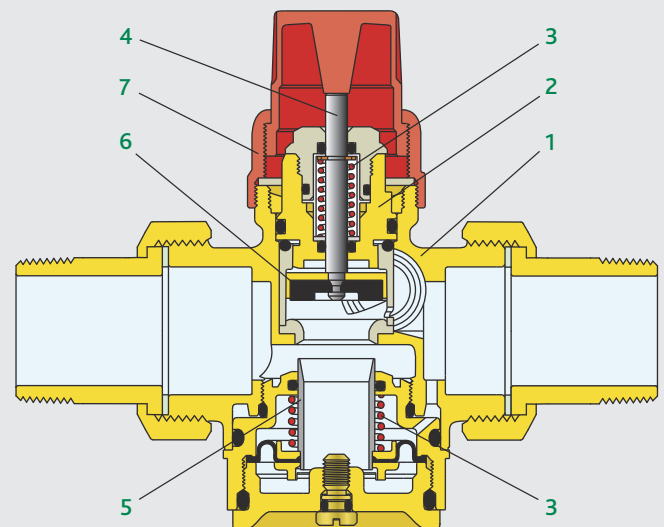

EPDM obturator

EPDM obturator (6) provides a perfect seal in the case of complete closing of the valve for circuit shut-off.

Compact design

The valve is of compact design with reduced dimensions and is easy to install.

Protective knob (7) can be removed by hand easily for flow rate regulation and when fitting the actuator.

Shut-off

The knob can be used to shut-off the circuit zone controlled by the valve.

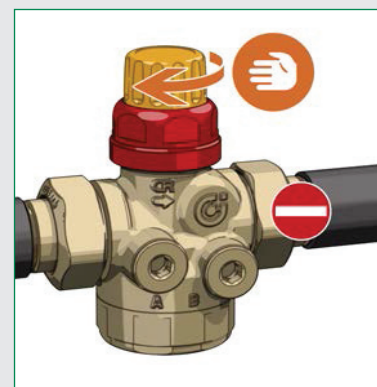

145 PICV pressure independent control valve

Construction Details

Pressure test ports

The valve is supplied with upstream and downstream connections for fast-plug pressure test ports (8), to be fitted in the connections with the system cold and not under pressure.

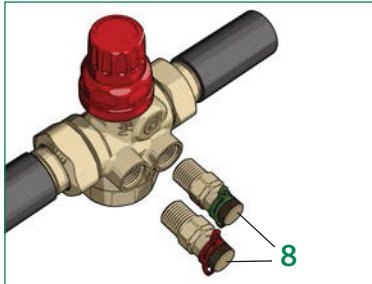

During operation the valve Δp generated by the fluid flow can be measured with a differential pressure meter (9).

By comparing this value with the selected Δp range, the corresponding actual flow rate can be determined.

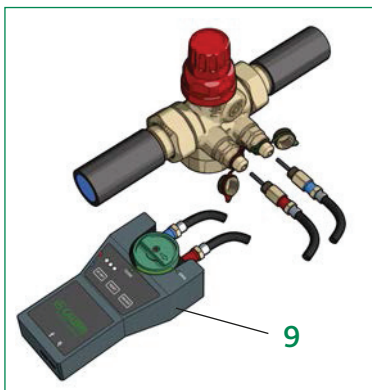

Proportional Linear Actuator

The valve is designed to accept a proportional linear actuator (code 145014). When connected to an electronic controller the valve can modulate the flow rate according to the demand for heating or cooling.

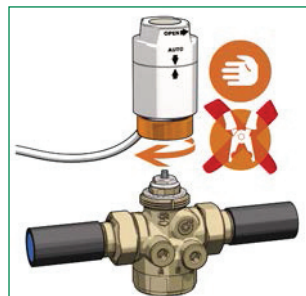
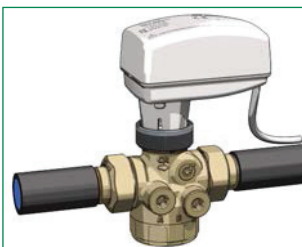

As an alternative to a proportional linear actuator, the valve can also be controlled with an ON/OFF type thermoelectric actuator for simpler temperature control logic.

Construction Details

Installation versatility

Without an actuator the valve can be installed in any position.

With an actuator the valve can be installed in any position except upside down.

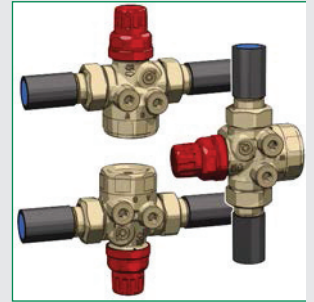
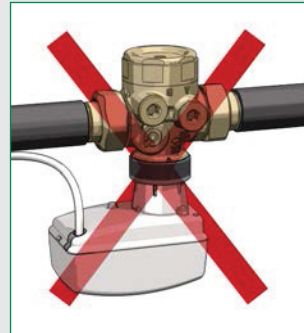

Adjustment Procedure

Maximum flow rate adjustment

Unscrew the protective plug by hand to gain access to the maximum flow rate adjustment nut (10), which can be turned with a hexagonal wrench.

The adjustment nut is fixed to a 10-position graduated scale,

divided into steps corresponding to 1/10 of the maximum available flow rate, which is also shown on the scale (11).

Turn the adjustment nut to the numerical position corresponding to the required flow rate (design flow rate), referring to the "Flow rate adjustment table".

The notch (12) on the valve body is the physical positioning reference.

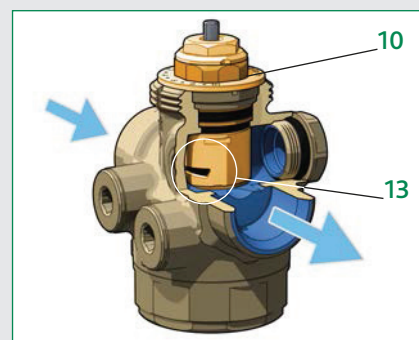
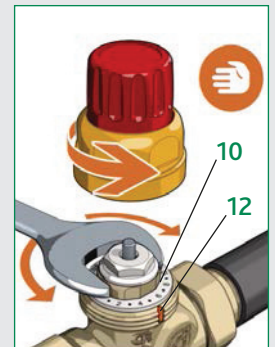

Turning adjustment nut (10), which determines the number associated with the "Adjustment position", results in opening/closing of the bore cross section in the external obturator (13). Hence, each bore cross section set on the adjustment nut corresponds to a specific G_{max} value.

145 PICV pressure independent control valve

Adjustment Procedure

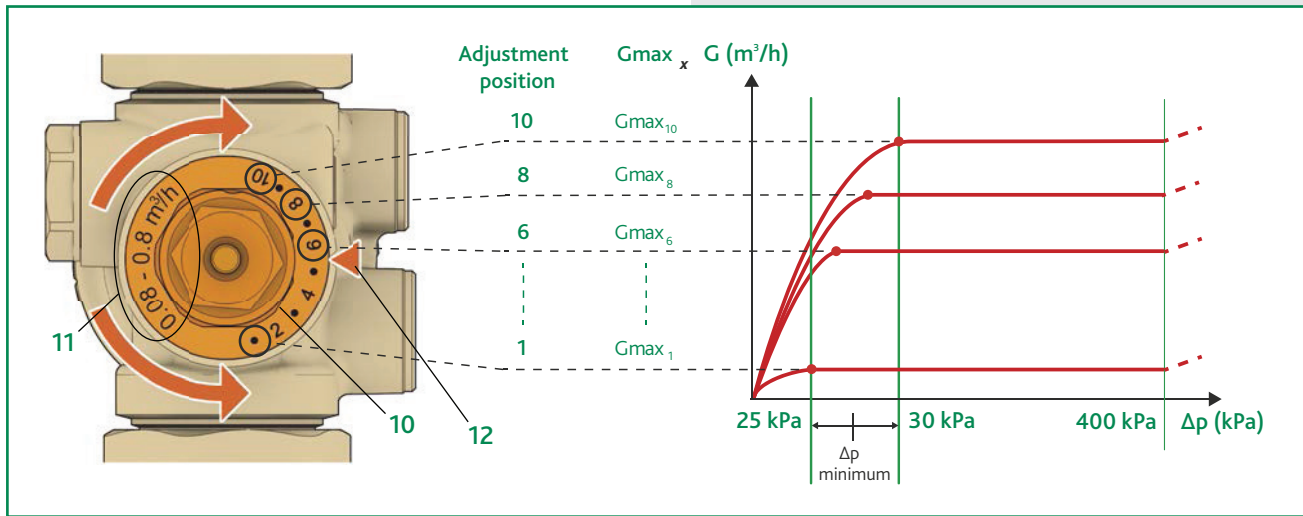

Automatic flow rate adjustment with actuator and external regulator

After adjusting the maximum flow rate, fit the actuator (0–10 V) code 145014 (14) to the valve.

When connected to an electronic controller the actuator can automatically adjust the flow rate from the maximum set value e.g. G_{max_8} to the minimum value in accordance to the demand for heating or cooling.

The actuator acts on the vertical displacement of control stem (4).

This results in additional opening/closing, on the maximum flow path cross section, by the internal obturator (15).

For example, if the maximum flow rate has been set to position 8, the flow rate can be adjusted automatically by the actuator from G_{max_8} to completely closed (zero flow rate).

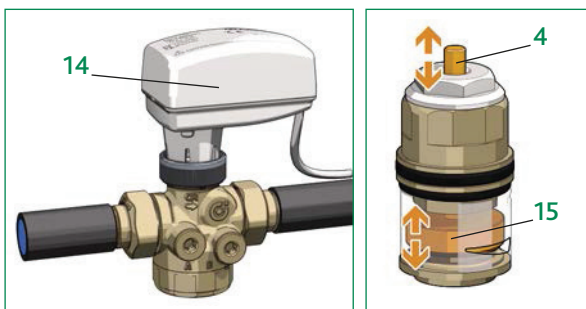

Flow rate adjustment curve

The valve adjustment curve is of the linear type.

An increase or decrease in the valve opening cross section corresponds to a directly proportional increase or decrease of the device's hydraulic coefficient K_v .

This characteristic produces the following benefits: the flow rate can be fine-tuned to intermediate/partial values that can be fully controlled in terms of modulation for optimal tracking of changes in the demand for heating or cooling.

Automatic and servo-assisted control is achieved with 0–10 V actuators, which are widely used for this type of applications.

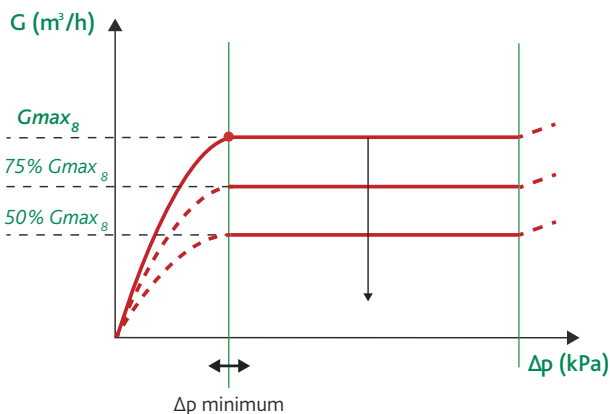
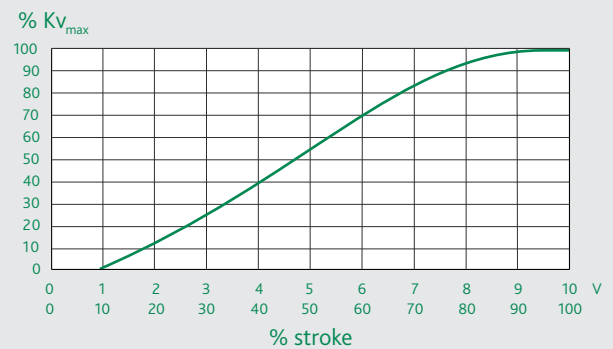

145 PICV pressure independent control valve

Flow Rate Adjustment Table

Code nut colour/range G	DN	Size		Adjustment positions									
				1	2	3	4	5	6	7	8	9	10
145420 H20 ● 0.08 - 0.40 m ³ /h	15	3/8"	Flow rate -m ³ /h	0.02	0.04	0.06	0.08	0.10	0.12	0.14	0.16	0.18	0.20
			Δp min - kPa	25	25	25	25	25	25	25.5	25.5	26	28
145430 H40 ○ 0.08 - 0.40 m ³ /h	15	3/8"	Flow rate -m ³ /h	-	0.08	0.12	0.16	0.20	0.24	0.28	0.32	0.36	0.40
			Δp min - kPa	-	25	25.5	26	26	26.5	26.5	27	27	27
145430 H80 ● 0.08 - 0.80 m ³ /h	15	3/8"	Flow rate -m ³ /h	0.08	0.16	0.24	0.32	0.40	0.48	0.56	0.64	0.72	0.80
			Δp min - kPa	25	25	25.5	26	26	27	27.5	28	28.5	29
145440 H40 ○ 0.08 - 0.40 m ³ /h	15	1/2"	Flow rate -m ³ /h	-	0.08	0.12	0.16	0.20	0.24	0.28	0.32	0.36	0.40
			Δp min - kPa	-	25	25.5	26	26	26.5	26.5	27	27	27
145440 H80 ● 0.08 - 0.80 m ³ /h	15	1/2"	Flow rate -m ³ /h	0.08	0.16	0.24	0.32	0.40	0.48	0.56	0.64	0.72	0.80
			Δp min - kPa	25	25	25.5	26	26	27	27.5	28	28.5	29
145550 H40 ○ 0.08 - 0.40 m ³ /h	20	3/4"	Flow rate -m ³ /h	-	0.08	0.12	0.16	0.20	0.24	0.28	0.32	0.36	0.40
			Δp min - kPa	-	25	25.5	26	26	26.5	26.5	27	27	27
145550 H80 ● 0.08 - 0.80 m ³ /h	20	3/4"	Flow rate -m ³ /h	0.08	0.16	0.24	0.32	0.40	0.48	0.56	0.64	0.72	0.80
			Δp min - kPa	25	25	25.5	26	26	26	26.5	26.5	27	27
145550 1H2 ● 0.12 - 1.20 m ³ /h	20	3/4"	Flow rate -m ³ /h	0.12	0.24	0.36	0.48	0.60	0.72	0.84	0.96	1.08	1.2
			Δp min - kPa	25	25	25.5	26	26	26.5	26.5	27	27.5	28
145560 H40 ○ 0.08 - 0.40 m ³ /h	20	1"	Flow rate -m ³ /h	-	0.08	0.12	0.16	0.20	0.24	0.28	0.32	0.36	0.40
			Δp min - kPa	-	25	25.5	26	26	26.5	26.5	27	27	27
145560 H80 ● 0.08 - 0.80 m ³ /h	20	1"	Flow rate -m ³ /h	0.08	0.16	0.24	0.32	0.40	0.48	0.56	0.64	0.72	0.80
			Δp min - kPa	25	25	25.5	26	26	26	26.5	26.5	27	27
145560 1H2 ● 0.12 - 1.20 m ³ /h	20	1"	Flow rate -m ³ /h	0.12	0.24	0.36	0.48	0.60	0.72	0.84	0.96	1.08	1.2
			Δp min - kPa	25	25	25.5	26	26	26.5	26.5	27	27.5	28
145552 H40 ○ 0.08 - 0.40 m ³ /h	20	3/4"	Flow rate -m ³ /h	-	0.08	0.12	0.16	0.20	0.24	0.28	0.32	0.36	0.40
			Δp min - kPa	-	25	25.5	26	26	26.5	26.5	27	27	27
145552 H80 ● 0.08 - 0.40 m ³ /h	20	3/4"	Flow rate -m ³ /h	0.08	0.16	0.24	0.32	0.40	0.48	0.56	0.64	0.72	0.80
			Δp min - kPa	25	25	25.5	26	26	26	26.5	26.5	27	27
145552 1H2 ● 0.12 - 1.20 m ³ /h	20	3/4"	Flow rate -m ³ /h	0.12	0.24	0.36	0.48	0.60	0.72	0.84	0.96	1.08	1.2
			Δp min - kPa	25	25	25.5	26	26	26.5	26.5	27	27.5	28

Minimum differential pressure required

To choose the pump you need, add the minimum pressure difference required by the valve to the fixed head losses of the most disadvantaged circuit. This value corresponds to working range starting Δp_{min} value shown in the table ($H_{\text{pump}} = \Delta p_{\text{circuit}} + \Delta p_{\text{min}}$).

145 PICV pressure independent control valve

Typical Applications

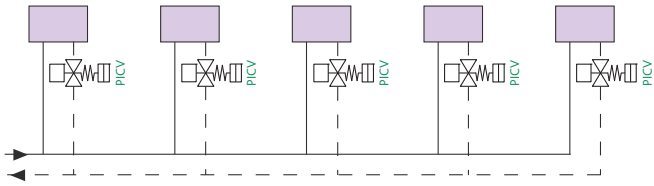

For use with various types of heat emitter, radiators, convectors, fan convectors, perimeter heating etc

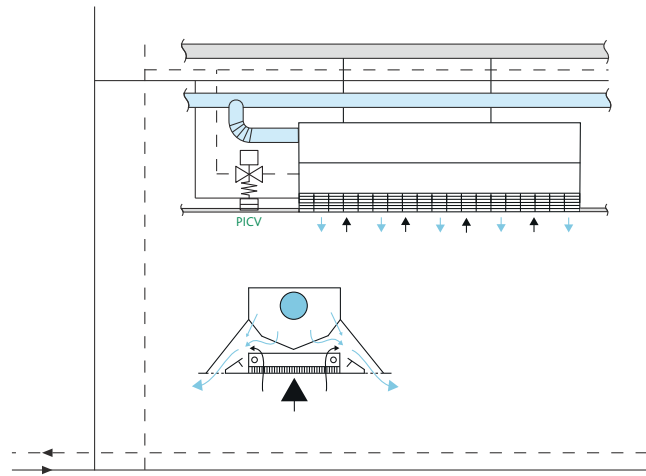

To adjust the flow rate to chilled beams

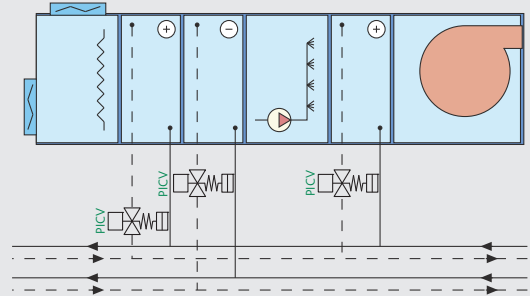

To balance circuits that serve air conditioning units

© Patents & Design Altecnic 2019

Altecnic Ltd retains all rights (including patents, designs and copyrights, trademarks and any other intellectual property rights) in relation to all information provided on or via the website, brochures or any other documents, including all texts, graphics and logos, contained on the website, in brochures or in any other documents published in the name of or on behalf of Altecnic Ltd in any form, without prior written consent of Altecnic Ltd.

Altecnic Ltd Mustang Drive, Stafford, Staffordshire ST16 1GW

T: +44 (0)1785 218200 E: sales@altecnic.co.uk

Registered in England No: 2095101

altecnic.co.uk

AL 223 09-10-2019

E & O.E

© Altecnic Limited. 2019

ALTECNIC™

altecnic
CALEFFI group