

118 CAVSA

kinetic air valve



altecnic

118 CAVSA automatic air vent



Application

This valve has been designed for the efficient discharge and intake of air in water systems, filtering systems, containers, and other places where confined air could impair the system's operation. The valve is appropriate for:

- Expelling the air at high flow velocity during filling the system
- Introducing large quantities of air when the pipe is being drained, maintaining atmospheric pressures in the pipe and preventing collapse and cavitation damage.
- Relieving entrained air from the water while the system is pressurised.

Design

Leak-proof sealing under all conditions, including at low system pressure.

The aerodynamic design of the float provides air flow at a very high velocity. The float does not close before the water has reached the valve.

The float does not close before the water has reached the valve.

The threaded outlet elbow allows various possibilities of drain connection.

The valve design contains a very limited number of parts, allowing easy dismantling for maintenance.

The design includes a non-return valve which allows air and water to pass through when attached to the air valve.

Operation

The valve has three modes of operation:

Discharging large quantities of air at a high flow velocity when the system is being filled.

When water enters the valve, the float rises up and closes the outlet.

Introduction of air into the pipeline when the internal pressure is sub-atmospheric.

The pressure difference forces the float to drop to "opened" position, allowing large volumes of air to flow into the pipe.

The pressurised air expels the water.

The ascending water level moves the main float with it. At a certain position the main float pulls down the small seal that partially opens the nozzle.

The pressurised air escapes, the water level rises and the nozzle closes.

Operation Continued

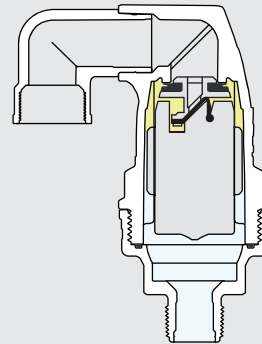

Pipe is full of water

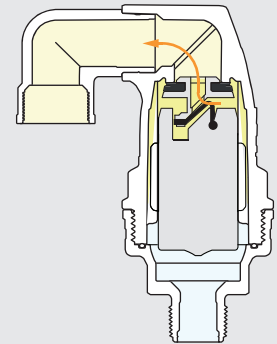

Dissolved air is accumulated in the valve, when released the float drops down

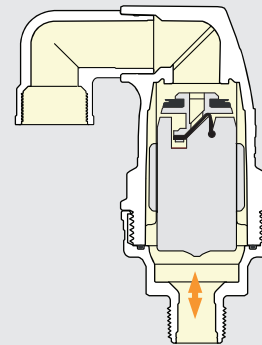

Pipe is aerated

118 CAVSA automatic air vent

Non-return Valve Surge Arrester

The CAVSA valve incorporates a float mechanism together with an adapted non- return valve.

The float ensures that a riser, when full, is hydraulically isolated from the atmosphere.

If the riser becomes partially emptied the adapted non return valve allows atmospheric pressure to enter the riser in order to prevent a vacuum forming within.

It also has the ability to expel the introduced atmospheric pressure gradually in a controlled manner as the riser is once again filled with water by the booster set.

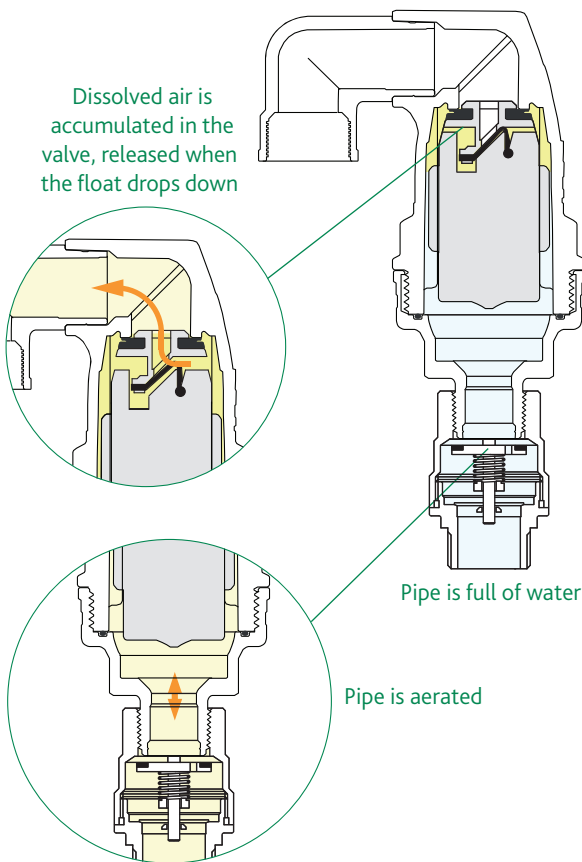

Dimensions

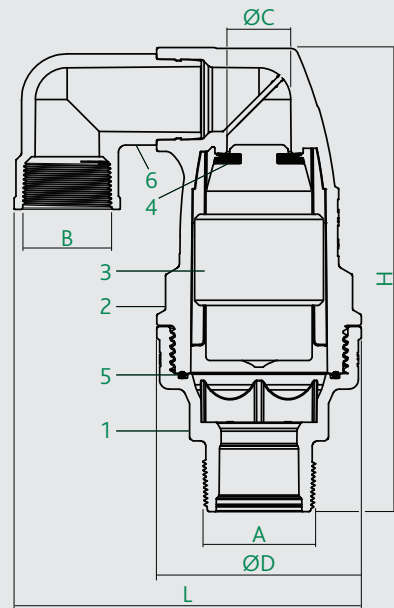

Prod Code	A	B	C*	D	H	L	kg
118-2001	R½	Rc¾	314	86	183	134	0.47
118-2002	R¾	Rc¾	314	86	183	134	0.47
118-2003	R1	Rc¾	314	86	183	134	0.47
118-2004	R2	Rc1½	908	110	249	187	1.052

* Nozzle area in mm²

Construction Details

Item	Component	Material
1	Body	Glass reinforced nylon Option - brass
2	Bonnet	Glass reinforced nylon
3	Float	Formed polypropylene
4	Kinetic seal	EPDM elastomer
5	'O' rings	NBR elastomer
6	Drainage elbow	Polypropylene

Technical Data

Medium:	water glycol solution
Max. percentage of glycol:	30%
Operating pressure:	0.2 to 16 bar
Working temperature:	-10 to 70°C

Must be insulated below 0°C

Discharge volume of air @ pipe pressure of 0.5 bar:		
	½"	70 m ³ /h
	¾"	170 m ³ /h
	1"	300 m ³ /h
	2"	700 m ³ /h

WRAS approved products

Installation

The kinetic air valve must be fitted at the highest point in the circuit.

If the installation has multiple risers a valve must be fitted on each riser.

The valve should NOT be fitted with an isolating valve.

It is recommended that an isolation valve is fitted should maintenance be required, a full bore valve with a lockshield or locking device can be used, locked in the fully open position.

The kinetic air valve during normal operation will discharge a small amount of water as the float seats against the body.

The amount of water discharged can vary between a few drops to a few ml.

The discharge should be pipe away from the drainage elbow to a suitable drain to prevent water damage.

It is recommended that the discharge is via a suitable tundish, to allow the discharge to be viewed and monitored.

Performance

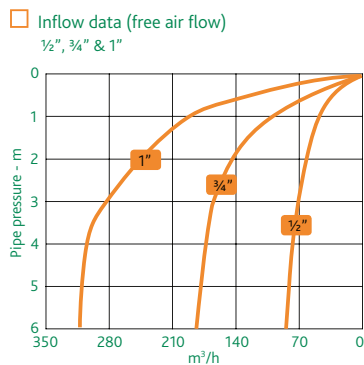
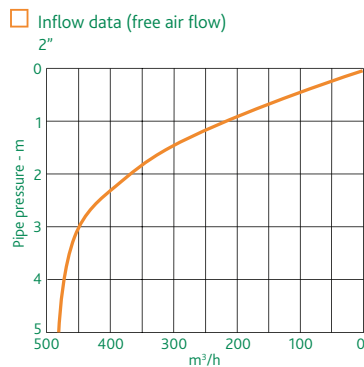

Maintenance

The Kinetic air valve does not require regular maintenance.

However, if the water discharge is excessive or prolonged the valve should be inspected for damage or debris from preventing the float from seating correctly.

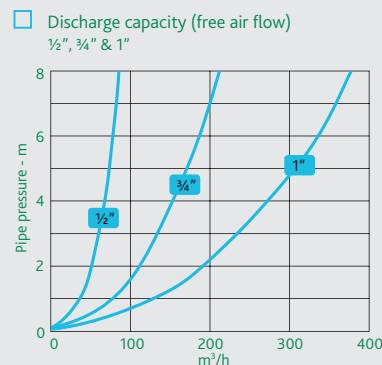
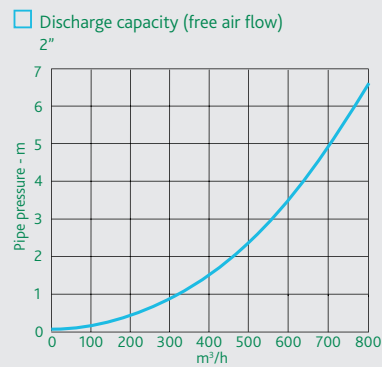

© Patents & Design Altecnic 2019

Altecnic Ltd retains all rights (including patents, designs and copyrights, trademarks and any other intellectual property rights) in relation to all information provided on or via the website, brochures or any other documents, including all texts, graphics and logos, contained on the website, in brochures or in any other documents published in the name of or on behalf of Altecnic Ltd in any form, without prior written consent of Altecnic Ltd.

Altecnic Ltd Mustang Drive, Stafford, Staffordshire ST16 1GW

T: +44 (0)1785 218200 E: sales@altecnic.co.uk

Registered in England No: 2095101

altecnic.co.uk

AL 320 22-07-19

E & O.E

© Altecnic Limited. 2018

ALTECNIC™