

101-300 mixcal careflo plus tmv3

Dimensions

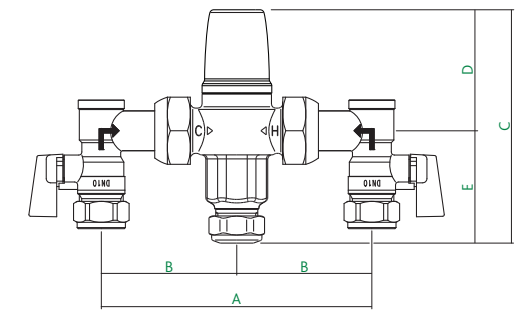
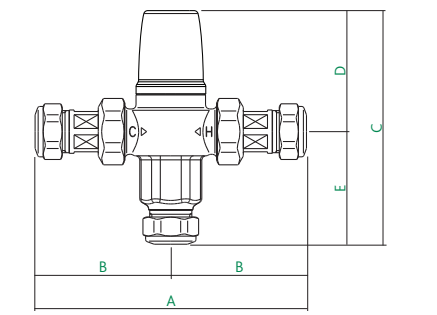

A	B	C	D	E	Weight
150mm	75mm	100mm	60.2mm	57mm	0.6 kg
136mm	68mm	100mm	60.2mm	57mm	0.75 kg

Insulation Cover
An insulation cover is optionally available (not shown) - product code CBN521815

- Problem Solving**
The following details are supplied for on site queries, should you require any further assistance contact our Technical Department.
- Hot water at the cold tap**
 - Operation of the insert check valves is hindered, check the valve is seated correctly.
 - Check Valves not fitted.
 - Unbalanced hot/cold supply pressure.
 - Fluctuating mixed water temperature**
 - Erratic supply temperatures at the inlets of the valve.
 - Starvation of the water supplied at the inlets of the valve.
 - Incorrect commissioning of the valve.
 - Erratic flow**
 - Insufficient water supplies.
 - Fluctuations in the supply pressures/temperatures.
 - Adverse effect created by other draw off points on the system.
 - No flow/reduced flow from valve**
 - In line filters are blocked.
 - Insufficient supply pressure.
 - Debris obstructing valve operation.
 - Valve requires servicing (Servicing kits available on request).
 - Valve does not fail safe when tested**
 - Installation not in accordance with our recommendations.
 - The minimum temperature differential not achieved.
 - Internal mechanism hindered by debris.

Full and detailed instructions are supplied with service kits and are available on request.

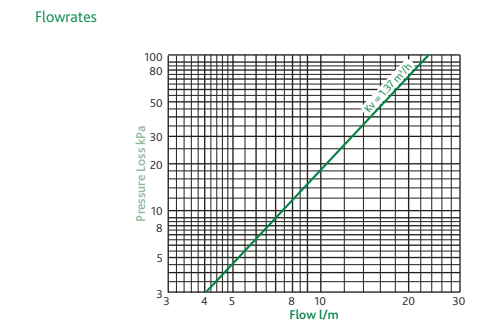

Spares
A full range of spares are available for this product from Altecnic.

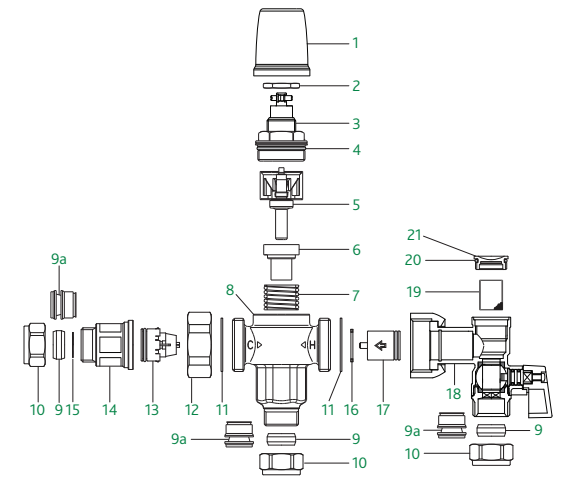

Item	Component	Item	Component
1	Cap	11	Gasket
2	Temperature Locking Ring	12	Union Nut
3	Valve Head Assembly	13	Check Valve Cartridge
4	Head Assembly 'O' Ring	14	Inlet Tail Housing
5	Thermostatic Element	15	Inlet Tail Filter
6	Flow Conveyor	16	Check valve Retaining Ring
7	Spring	17	Check Valve Cartridge
8	Valve Body	18	Inlet Tail Housing
9	22mm Olive	19	Screen
9a	15 to 22mm Adaptor	20	Access Cap 'O' ring
10	Compression Nut	21	Access Cap

Temperature Adjustment

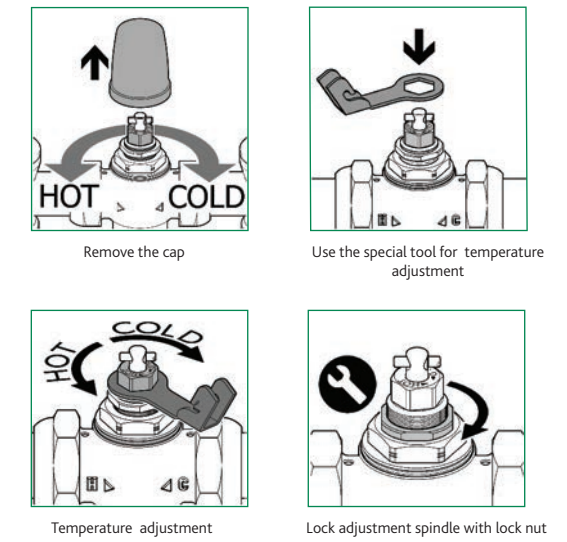

- Remove the cap from the valve
- Remove the temperature locking ring from the spindle using a suitably sized spanner
- Open the outlet to which the mixing valve is supplying and establish a stable flow and temperature
- Using a calibrated thermometer place the sensing part of the thermometer probe under the flowing water
- Using the special tool provided turn the temperature adjustment spindle anticlockwise to increase the mixed water temperature or clockwise to reduce the mixed water temperature – at all times ensuring the probe of the thermometer is under the flowing water.
- Once the desired temperature is reached – replace the temperature locking ring on the spindle and refit the cap of the valve.
- The temperature at the terminal fitting must never exceed 46°C.

Override Operation

The override function allows thermal disinfection against Legionella to be performed using the special tool.
The special tool lifts the spindle, by-passing the operation of the thermostatic cartridge.
The higher temperature hot water passes through the valve and pipework to disinfect it.
WARNING: During this operation the hot water from any outlet on the system must **NOT** be used for washing or bathing as the water is at an unsafe temperature.

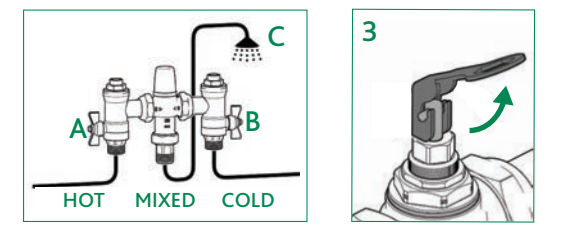

- Close hot and cold water inlet isolating valves (A and B).
- Remove the top cover.
- The valve requires the thermal purge to be undertaken prior to performing the regular cold water isolation test on the thermostatic valve i.e. purge, check the temperature and then undertaken the cold water isolation test.
- Using the special tool, lift the spindle to its upper position, leaving the tool in place, by-passing the thermostatic cartridge operation.
- Open the hot water isolating valve (A) and open a water outlet point like a tap (C).
- Perform the thermal purge with hot water on all taps in the system.
- Close the hot water inlet (A) and any water outlets (C).
- Put the spindle back to its original position, removing the tool.
- The valve's mixed water set temperature remains at the value that was set during commissioning.
- Open the hot and cold water isolating valve (A and B).
- The TMV is now back to its normal working condition.

Please leave these instructions for the user

© Patents & Design Altecnic 2020
Altecnic Ltd retains all rights (including patents, designs and copyrights, trademarks and any other intellectual property rights) in relation to all information provided on or via the website, brochures or any other documents, including all texts, graphics and logos, contained on the website, in brochures or in any other documents published in the name of or on behalf of Altecnic Ltd in any form, without prior written consent of Altecnic Ltd.
Altecnic Ltd Mustang Drive, Stafford, Staffordshire ST16 1GW
T: +44 (0)1785 218200 E: sales@altecnic.co.uk
Registered in England No: 2095101
altecnic.co.uk
IOM 150 31-03-21
E & O E
© Altecnic Limited. 2020
ALTECNIC™



101-300
mixcal careflo plus tmv3

Installation & Maintenance Instructions



101-300 mixcal careflo plus tmv3

Introduction
The Altecnic 101-300 mixcal careflo plus thermostatic mixing valves have been specifically designed and manufactured to meet the requirements of BS 7942: 2011 and NHS D 08. The valve has been independently tested and approved as a TYPE 3 valve under the TMV3 scheme.

Technical Specification / Conditions for use TMV3 Valves

Outlet Temperature Adjustment Range	30°C to 50°C
Temperature Stability	±2°C
Maximum Hot Inlet Temperature	85°C
Inlet Temperature Range	55°C to 65°C : Hot Supply 5°C to 20°C : Cold Supply
Max. Working Pressure	10 bar : Static
Min. Working Pressure	0.2 bar : Dynamic
D 08 Working Pressure Range	0.2 to 1.0 bar : Low Pressure 1.0 to 5.0 bar : High Pressure
Min Temp Differential (Mix to Hot) for Fail-Safe	10°C
Max. Pressure Inlet Differential	5 : 1
Max. Flow Rate @ 1 bar Differential	Ø15mm 1500 l/hr (25 l/m) Ø22mm 1700 l/hr (28.3 l/m)

NOTE: Valves operating outside these conditions cannot be guaranteed by the Scheme to operate as Type 3 valves.

Approvals

TMV3 Scheme Approval Number	Details Available on Request
WRAS Scheme Approval Number	Details Available on Request

Fail Safe Function
Altecnic 101-300 valves are designed to stop the mixed water flow in the event of either the hot or cold water supply failing when installed in accordance with these instructions. To ensure full closure of the mixed water flow the minimum temperature differential between the hot water inlet to the valve and the mixed water outlet MUST be at least 10°C.

Application
Altecnic 101-300 mixcal careflo plus thermostatic mixing valves have been independently tested and certified by NSF as meeting the requirements of the NHS D 08 specification under the TMV3 Scheme as being suitable for use on the following designations.

Application

Code	Application	Range	Code	Application	Range
HP-W	Basin	High Press	LP-WE	Basin	Low Press
HP-B	Bidet	High Press	LP-BE	Bidet	Low Press
HP-S	Shower	High Press	LP-SE	Shower	Low Press
HP-T44	Bath Assisted*	High Press			
HP-T46	Bath Assisted*	High Press			

Dimensions
For dimensions see pages 13.

Flowrates
For Kv value and flowrate - pressure loss chart see page 15.

Installation
IMPORTANT: - The following instructions must be read prior to the installation of the 101-300 mixcal careflo plus thermostatic mixing valves. The installer should also be aware of their responsibility and duty of care to ensure that all aspects of the installation comply with all current regulations and legislation. It has been brought to our attention that flushing through water systems using certain chemicals may wholly or partially remove the lubricant from the internal workings of the valve, which may adversely affect its performance. We recommend that following flushing of the system with chemicals; valves are checked for correct operations. The installation of thermostatic mixing valves must comply with the requirements of the Water Supply (Water Fittings) Regulations 1999.

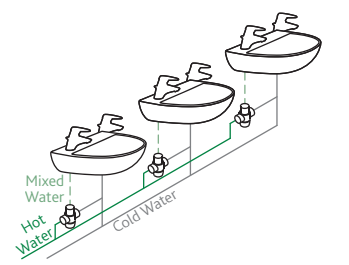

Installation
The 101-300 thermostatic mixing valves MUST be installed in an accessible position to ensure that maintenance, commissioning and testing of the 101-300 Thermostatic Mixing Valves can be undertaken easily.

- It is essential that before installing any thermostatic mixing valve to ensure that the supply conditions of the system to which the valve is intended to be fitted are checked to confirm compliance with the parameters as quoted within the Technical Specification and conditions on which the approval is granted i.e. verify supply temperatures, supply pressures, risk assessment.
- Consideration must be made for the possibility of multiple/simultaneous demands being made on the supply system whilst the 101-300 valves are in use, all practical precautions must be made to ensure that the valve is not affected. Failure to make provision within the pipe sizing etc. will affect the performance of the valve.
- The supply system into which the 101-300 valves are to be installed must be thoroughly flushed and cleaned to remove any debris, which may have accumulated during the installation. Failure to remove any debris will affect the performance and the manufacturer's warranty of the product. Independent filters and isolation valves must be fitted in conjunction with the valve, as close as practically possible to the water supply inlets of the 101-300 thermostatic valve. In areas that are subject to aggressive water, provision must be made to treat the water supply prior to the supply entering any Altecnic product.
- The maximum flow rate of the valve will only be achieved when the supply conditions are achieved as quoted within the Technical Specification, with a flow condition under 1 bar differential pressure.
- 101-300 valves have been designed to ensure that the valve can be installed in any position whether vertical or horizontal, it can be surface mounted or within a supply duct. It is essential to install in an accessible position for maintaining and commissioning the valve.
- We recommend that the 101-300 thermostatic mixing valves be installed as close as practically possible to the outlet, which it is serving. In this situation attention must be paid to the maximum distance of pipe work from the mixed water outlet of the valve to any terminal fitting.
- Current guidelines recommend a maximum distance of 2 metres from the outlet of any mixing valve to the furthest terminal fitting/outlet to which the mixing valve is to serve.
- The hot and cold water supplies must be connected to the valve strictly in accordance with the indications on the body of the valve i.e. hot water supply to the hot port of the valve.
- In a situation where one or both of the water supplies are excessive, it is possible to fit a pressure reducing valve to reduce the pressure(s) to within the limits as quoted previously.

- Installation**
- Any thermostatic mixing valve must be fitted with a back flow prevention device, such as check valves to prevent the cross contamination of supplies. 101-300 valves are complete with integral insert check valves and strainers. However if required, additional WRAS approved backflow prevention devices should be positioned as close as practically possible to the water supply inlets of the thermostatic mixing valve. A complete range of backflow prevention devices are available to complement this product.
 - Y Pattern strainers and full-bore isolation valves must be installed in conjunction with the 101-300 fail-safe thermostatic mixing valves as close as practically possible to the location of the valve. Alternatively the use of the thermostatic mixing valve with the MX end pieces removes the need for additional filters and isolation valves.
 - It is essential that the 101-300 thermostatic mixing valve should not be installed in situations where there is a possibility of the valve being deprived of water or where demands for water are greater than the actual stored supplies.
 - To ensure that the performance levels of the 101-300 thermostatic mixing valves are maintained (in the event of cold water failure), the temperature of the hot water supply at the point of entry to the valves must be a minimum of 10°C above the commissioned mixed water discharge temperature.
 - 101-300 thermostatic mixing valves must not be subject to any extreme temperature variations either during the installation or under normal operating conditions.
 - If the 101-300 thermostatic mixing valve is to be installed into a 22mm copper pipe system use the standard 22mm olives, if it is to be installed into a 15mm copper pipe system use the 15 to 22 universal adaptor.

- Method of Adjusting the Mixed Water Outlet Temperature**
IMPORTANT: - The following instructions must be read and understood prior to the adjustment of the mixed water outlet temperature and this action MUST only be carried out by a suitably qualified or competent person.
- Remove the cap from the valve
 - Remove the temperature locking ring from the spindle using a suitably sized spanner
 - Open the outlet to which the mixing valve is supplying and establish a stable flow and temperature
 - Using a calibrated thermometer place the sensing part of the thermometer probe under the flowing water
 - Using the special tool provided turn the temperature adjustment spindle anticlockwise to increase the mixed water temperature or clockwise to reduce the mixed water temperature – at all times ensuring the probe of the thermometer is under the flowing water.
 - Once the desired temperature is reached – replace the temperature locking ring on the spindle and re fit the cap of the valve.
 - The temperature at the terminal fitting must never exceed 46°C.

Commissioning
IMPORTANT - The following instructions must be read and understood prior to the commissioning of the 101-300 fail-safe thermostatic mixing valves. If under any circumstances there are aspects to the installation / system which do not comply with the specification laid down, the valve MUST NOT be put into operation until the system / installation complies with our specification. However if all these conditions are met, proceed to set the temperature as follows;

- Ensure that the system is thoroughly cleaned and free from any debris prior to the commissioning the Altecnic fail-safe thermostatic mixing valves.
- Commissioning the temperatures must be carried out using a suitably calibrated thermometer - preferably a digital thermometer.

Table 1

Application	Recommended Set Mixed Water Temp.
Wash Hand Basin	41°C
Shower	41°C
Bidet	38°C
Bath Fill	44°C

- Note 1:** For washbasins, washing under running water is assumed.
Note 2: Bath fill temperatures of more than 44°C should only be available when the bather is always under the supervision of a competent person (e.g. nurse or care assistant).
Note 3: The 101-300 thermostatic mixing valve is capable of satisfying all the individual applications and should be re-set on-site to meet the designated application.

- In the absence of other temperatures being specified, we recommend the outlet temperatures quoted in Table 1.
- Each valve must be commissioned taking into consideration any fluctuations, which may occur within the system due to simultaneous demands. It is advisable that any outlets which are connected to the same supply as the mixing valve are opened during the setting of the mixed water temperature. During commissioning it is advisable to ensure that the water temperatures are established before any attempt to commission.
- Once the supply temperatures are stable and the normal operating conditions are established, the valve can be commissioned. The temperature setting can be adjusted by removing the cap and locking ring from the valve body and adjusting the temperature adjustment spindle. We suggest that the following sequence is followed when commissioning the valve:
 - Set the mixed water temperature to the required temperature.
 - Measure and record the temperature of the hot and cold water supplies at the connection to the valve.
 - Measure and record the temperature of the water discharging from the valve from the largest and smallest draw off point.
 - Isolate the cold water supply to the valve and monitor the mixed water temperature.

Commissioning

- Measure and record the maximum mixed water temperature and the final temperature. The final temperature found during the test should not exceed the values quoted in Table 2.
- Record all the equipment used during the commissioning.

Table 2

Application	Maximum Set Mixed Water Temp.
Wash Hand Basin	43°C
Shower	43°C
Bidet	40°C
Bath Fill - unassisted	44°C
Bath Fill - assisted	46°C

- Note:** Bath fill temperatures of more than 44°C should only be available when the bather is always under the supervision of a competent person (e.g. nurse or care assistant).
- Once the desired temperature is established remove the cap and secure the temperature spindle with the locking ring and replace the cap into its original position to prevent tampering by unauthorized persons.
 - Ensure that the application, in which the valve will be used, is appropriate for the approved designation. The above information must be recorded and updated on every occasion when any work is carried out on the valve.

Maintenance
To ensure that the 101-300 valves maintain a high level of protection, we advise the following in service testing is conducted (the same equipment used to commission the valve initially must be used in the following tasks).

- After a period of between 6 and 8 weeks from commissioning carry out the following:
 - Record the temperature of the hot and cold water supplies.
 - Record the temperature of the mixed water at the largest draw off flow rate.
 - Record the temperature of the mixed water at the smallest draw off flow rate.
- If the mixed water temperature has changed significantly from the previous test results (e.g. >1°C), record the change and before resetting the mixed water temperature check that:
 - All the strainers are clean (see Installation 3).
 - All the check valves are in good working order (see Installation 9).
 - The isolation valves are fully open

Maintenance

- If the mixed water temperatures are acceptable, carry out the following:
 - Record the temperature of the hot and cold water supplies
 - Record the temperature of the mixed water at the largest draw off flow rate
 - Record the temperature of the mixed water at the smallest draw off flow rate
 - Isolate the cold water supply to the mixing valve and monitor the mixed water temperature
 - Record the maximum temperature achieved as a result of (3.4) and the final temperature (the final temperature should not exceed the values quoted in table 2)
 - Record the equipment used during these tests
- If the mixed water temperature is greater than the values quoted in table 2 or the maximum the corresponding values from previous test results by more than 2°C, the valve must be serviced.
- After a period of between 12 to 15 weeks from commissioning, carry out the sequence of tests as described in Maintenance sections 1, 2, 3 and 4.
- Dependant upon the results obtained from the first two series of tests; there are a number of possible outcomes:
 - If no significant change in the mixed water temperatures (e.g. ≤ 1°C) is recorded between commissioning and Maintenance sections 1 or between commissioning and Maintenance sections 5, the next in service testing should be carried out at a period of 24 to 28 weeks after initial commissioning.
 - If a small change (e.g. 1 to 2°C) in the mixed water temperature is recorded in only one of these periods, necessitating adjustment of the mixed water temperature, then the next in service can be deferred to 24 to 28 weeks after commissioning.
 - If small changes (e.g. 1 to 2°C) in the mixed water temperature are recorded in both of these periods, necessitating adjustment of the mixed water temperature, then the next in service test can be deferred to 18 to 21 weeks after commissioning.
 - If significant changes (e.g. > 2°C) in the mixed water temperature are recorded in both of these periods necessitating service work, then the next in service test should be carried out at 18 to 21 weeks after commissioning.
- The general principle to be observed after the first 2 or 3 in-service tests is that the intervals for future tests should be set to those which previous tests have shown can be achieved with no more than a small change in mixed water temperature.
- In all areas periodic maintenance of the valve and associated fittings i.e. strainers, check valves will ensure optimum performance levels are maintained.

Problem Solving
For resolving on site problems see page 12.
Spares
For component identification see page 14.