

140-180 CST

fully lugged butterfly valve



altecnic

140-180 CST fully lugged butterfly valves



Introduction

The Altecnic fully lugged butterfly valves are suitable for a wide variety of applications including end of line service..

In-particularly they are suitable for a wide range of HVAC applications on both heating and chilled water systems.

Design

The valves have stainless steel discs and operating shafts offering excellent corrosion resistance.

The EPDM body liner and seals are suitable for temperatures up to 120°C.

Valves feature a long neck to allow insulation by lagging or valve box.

Valves are supplied as standard with locking lever but can be supplied with a manual gear operator when specified.

Valves are WRAS approved products for use on potable services.

The valves can be used to regulate the flow with good control characteristics.

Mounting flange for levers, gear operators and electric or pneumatic actuators complies with BE EN ISO 5211.

Materials

Component	Material	
Body:	Ductile iron	
Disc:	Stainless steel	
Shafts:	Stainless steel	
Body liner:	EPDM	
Bush:	PTFE	
Circlip:	Steel	
Seals:	Viton	
Level:	Aluminium	Up to DN150
	Ductile iron	DN200 to DN250

Technical Specification

Generally conforms to BS EN 593:2009

Epoxy coated ductile iron body

Fully threaded holes in the connection flange lugs

Stainless steel disc and shafts

EPDM liner

Mounting flange to BS EN ISO 5211

Locking lever available for sizes up to DN250

Manual gear operator available for all sizes

To suit flange connections BS EN1092-2 PN16 or PN10

Complies with 97/23CE (PED) Directive CE1115

WRAS approved product

Test Pressures - Hydrostatic

Shell = 24 bar

Seat = 17.6 bar

Pressure Temperature Rating

PN16 from -10°C to 120°C

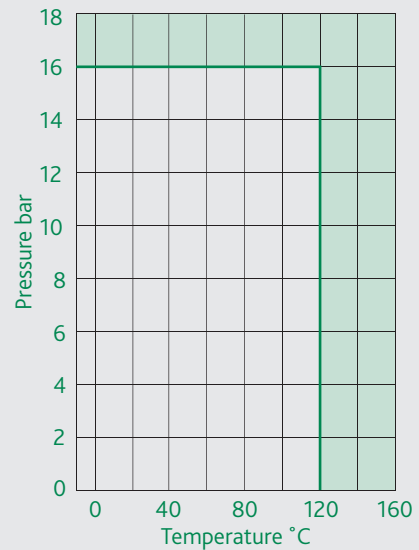

140-180 CST fully lugged butterfly valves

Dimensions

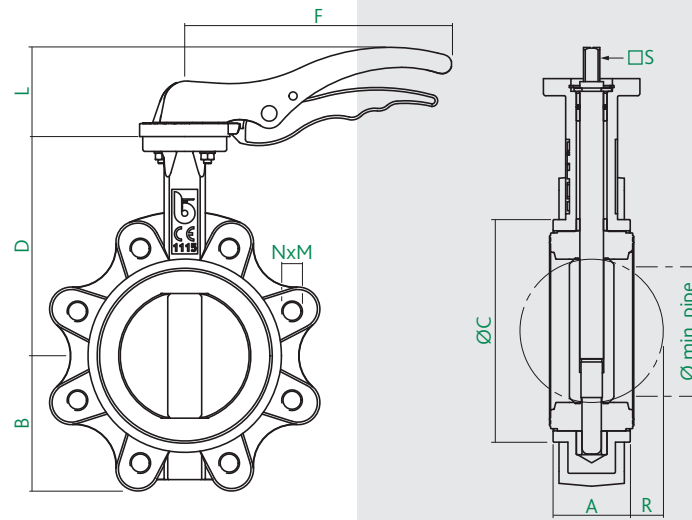

Ref No	Size	A	B	C	D	F	L	R	S	NxM	Ø min. pipe	Mounting Flange
140-1801 CST	DN40	33	63	82	116	170	50	5	9	4 x M16	27	F05
140-1802 CST	DN50	43	62	89	126	170	50	5	9	4 x M16	31	F05
140-1803 CST	DN65	46	69	102	136	170	50	9	9	4 x M16	45	F05
140-1804 CST	DN80	46	90	118	150	206	69	17	11	8 x M16	65	F05
140-1805 CST	DN100	52	106	150	170	206	69	26	11	8 x M16	90	F05
140-1806 CST	DN125	56	119	174	180	285	90	34	14	8 x M16	110	F07
140-1807 CST	DN150	56	131	205	200	285	90	50	14	8 x M20	146	F07
140-1808 CST	DN200	60	166	260	230	400	72	71	17	12 x M20	194	F10
140-1809 CST	DN250	68	202	318	266	530	72	91	17	12 x M24	241	F12

© Patents & Design Altecnic 2020

Altecnic Ltd retains all rights (including patents, designs and copyrights, trademarks and any other intellectual property rights) in relation to all information provided on or via the website, brochures or any other documents, including all texts, graphics and logos, contained on the website, in brochures or in any other documents published in the name of or on behalf of Altecnic Ltd in any form, without prior written consent of Altecnic Ltd.

Altecnic Ltd Mustang Drive, Stafford, Staffordshire ST16 1GW

T: +44 (0)1785 218200 E: sales@altecnic.co.uk

Registered in England No: 2095101

altecnic.co.uk

AL 385 05-10-20

E & O.E

© Altecnic Limited. 2020

ALTECNIC™