

UFH control unit

502-1053 - without pump

502-1050 - with pump

502-1060 - with pump
and unions

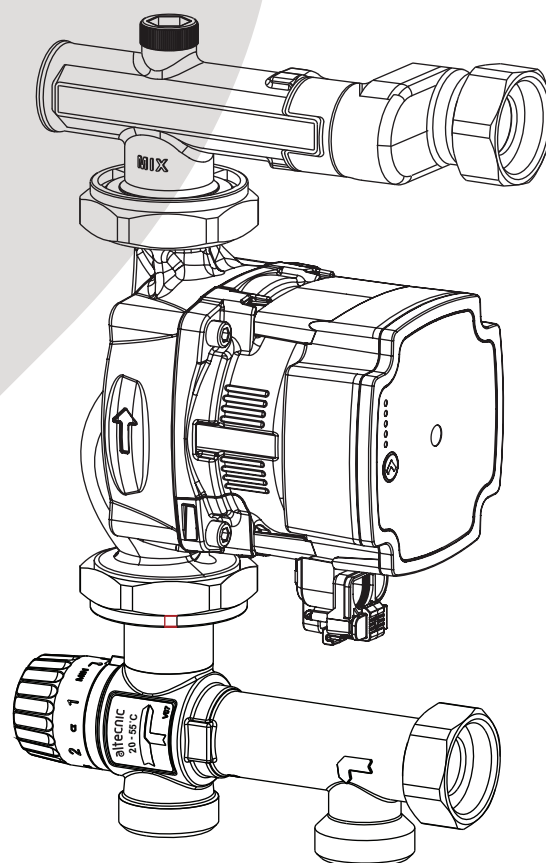

altecnic

502 - UFH Control Unit

Introduction

The UFH Control Unit is designed to supply temperature controlled hot water to the underfloor heating system or in radiant panel heating systems.

It is designed to be easily connected to any flow and return manifold (not supplied) with 200mm to 211mm centres, to evenly distribute the hot water.

The UFH Control Unit is supplied as a collection of components for easy assembly at site.

The offset elbow has 2 liquid crystal thermometers to indicate temperature and a test port which are used to install an air vent or pressure gauge.

The UFH Control Unit is normally supplied with the Grundfos UPM3 (K) pump but can also be supplied without a pump Ref No 502-1053.

Materials Specification

Flow elbow:	Brass	BS EN 12165 CW617N
Fittings for manifolds:	Brass	BS EN 12165 CW617N
Gasket:	Elastomer	EPDM
Thermometer:	Liquid crystal (LCD)	

Thermostatic mixing valve:

Body:	Brass	BS EN 12165 CW617N
Gasket:	Elastomer	EPDM
Headwork:	Brass	BS EN 1982 CB753S
Spring:	Stainless steel	AISI 302
Thermostatic sensor:	Wax	
Knob:	ABS	

Pump:

Grundfos:	UPM3 (K)	
Body:	Cast iron	
Gaskets:	Elastomer	EPDM
Electrical supply:	230 V 50/60 Hz	
Protection class:	IPx4D	
Centre distance:	130mm	
Connections:	G1½B	BS EN ISO 228-1

Technical Specification

Medium:	water or glycol solution
Maximum glycol percentage:	30%
Temperature range:	5 to 90°C
Temperature adjustment range:	35 to 60°C
Factory setting:	35°C
Accuracy:	±2°C
Maximum working pressure:	10 bar
Male thread connections:	BS EN ISO 228-1
Primary side connection centre distance:	75mm
Manifold connection centre distance:	200mm to 211mm

* A version of the UFH control unit is available from Altecnic without a pump Ref No 502-1053. The pump manufacturer's instruction booklet is only supplied when a pump is fitted.

Components

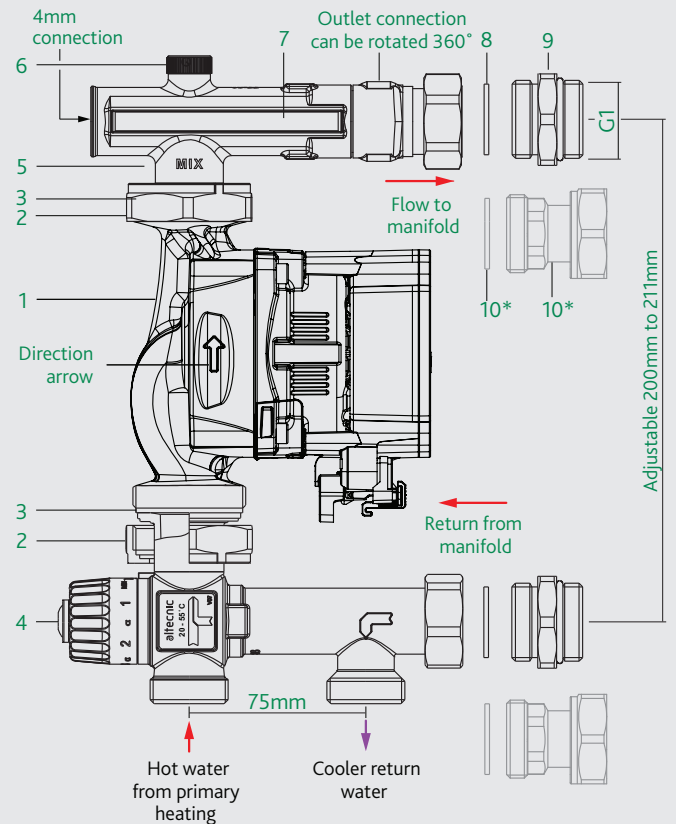

Item	Components
1	Pump - Grundfos UPM3 (K)
2	Pump nut - Qty 2
3	Pump washer - Qty 2
4	Thermostatic mixing valve
5	Flow elbow
6	Test plug
7	Liquid crystal thermometer - Qty 2
8	Manifold washer - Qty 2
9	Manifold fitting c/w 'O-ring' - Qty 2
10*	Manifold fitting c/w washer - Qty 2
11	Altecnic instructions
12^	Grundfos instructions

* items 10 are only supplied with the 502-1060

^ item 12 only supplied with 502-1050 and 502-1060

Left and Right Configurations

The control unit can be configured with the manifold mixing unit on the left or right side of the flow and return manifolds.

The hot water and cold water connections and the flow and return connections of the control unit remain unaltered and must be connected using the flow arrows on the thermostatic mixing valve body.

502 - UFH Control Unit

Setting the Thermostatic Mixing Valve

Adjustment of the thermostatic mixing valve

The knob is equipped with an anti-tamper mechanism which makes the rotation difficult, thus avoiding undesired set changes.

The mechanism can be released with a screwdriver, slightly loosening the locking screw.

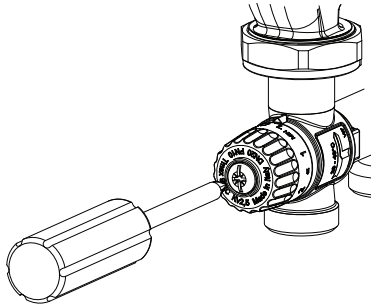

Setting the Thermostatic Mixing Valve

To change from the factory set temperature (35°C), proceed as follows:

- 1 The graduated scale on the knob corresponds to the temperature values shown in the table.

Min	1	2	3	4	5	Max	
35°C	43°C	48°C	50°C	53°C	57°C	60°C	35°C

- 2 With a screwdriver, slightly loosen the locking screw, holding the knob with your hand.
- 3 Set a mixed water temperature value slightly lower than the design temperature.

Turn on the hot water source and wait until it reaches its design working temperature (higher than the valve setting).

Turn on the manifold mixing unit pump. Wait until the mixed water temperature becomes stable. Read its value on the flow elbow where the liquid crystal thermometer is located.

Setting the Thermostatic Mixing Valve Continued

- 4 To increase the temperature rotate the knob slowly counter clockwise. Wait until the temperature becomes stable. Read its value on the flow elbow where the liquid crystal thermometer is located.
Repeat the procedure until the desired flow temperature is reached.

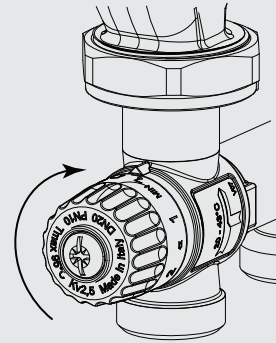

- 5 To reduce the temperature rotate the knob slowly clockwise following the procedure in '4'.

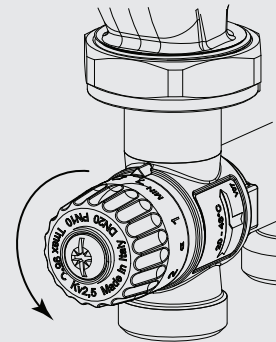

- 6 When the desired temperature is reached, re-tighten the locking screw, holding the knob with your hand.

© Patents & Design Altecnic 2025

Altecnic Ltd retains all rights (including patents, designs and copyrights, trademarks and any other intellectual property rights) in relation to all information provided on or via the website, brochures or any other documents, including all texts, graphics and logos, contained on the website, in brochures or in any other documents published in the name of or on behalf of Altecnic Ltd in any form, without prior written consent of Altecnic Ltd.

Altecnic Ltd Francesco House, Staples Close, Stafford ST16 1WQ

T: +44 (0)1785 218200 E: sales@altecnic.co.uk

Registered in England No: 02095101

altecnic.co.uk

AL 342 27-02-25

E & O.E

© Altecnic Limited. 2025

ALTECNIC™

altecnic