

127

automatic balancing  
valve



**altecnic**  
CALEFFI group

# 127 automatic balancing valve



## Introduction

The Altecnic automatic balancing valves (ABVs) are used to keep the flow rate constant, at the design value, in air conditioning and heating system.

They automatically balance the circuit by ensuring the design flow rate to each terminal unit irrespective of changes elsewhere in the system.

The valves are supplied with a cartridge manufactured from a high resistance polymer which gives good scale resistance and low noise when used in water systems.

A range of flow cartridges are available cover the range of 0.033 l/s to 0.44 l/s.

Altecnic 127 automatic balancing valves are designed with a compact body for ease of installation to individual terminal units.

## Product Range

127 Automatic balancing valve with polymer cartridge.

## Materials

Component	Material	Grade
Body	Brass	BS EN 12164 CW614N
Cartridge:	Polymer	
Spring:	Stainless steel	BS EN 10270-3 (AISI 302)
Seals:	EPDM	

## Technical Specification

Medium:	Water glycol solution
Max. percentage glycol:	50%
Max. working pressure:	16 bar
Max. temperature range:	0 to 100°C
Δp range:	15 to 200 kPa
Flow range:	0.12 to 1.6 m <sup>3</sup> /h 0.033 to 0.44 l/s
Accuracy:	±10%

## Connections

Female: ½" and ¾"

## Dimensions

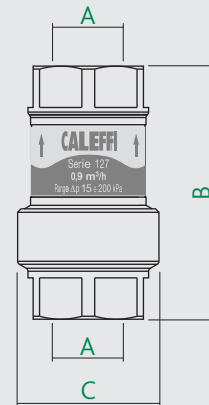

Code	A	B	C	kg
127141	Rc½	74	41	0.24
127151	Rc¾	74	41	0.25

## Circuit Balancing

Modern heating and air-conditioning systems have to guarantee a high level of thermal comfort with a low energy consumption.

This means supplying the terminal emitters with the correct design flow rates, to produce balanced hydraulic circuits.

## Unbalanced Circuits

In case of an unbalanced circuit, the hydraulic imbalance between emitters creates areas with temperatures which are not uniform, and, as a consequence, problems with thermal comfort and higher energy consumption.

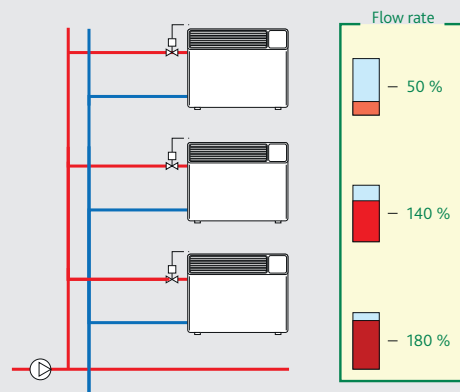
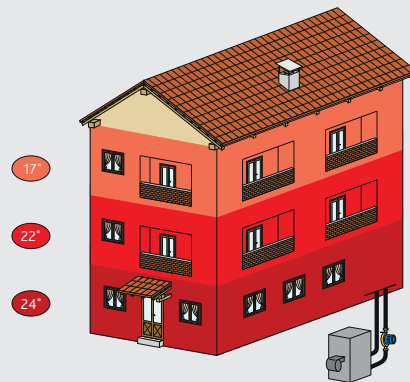

# 127 automatic balancing valve

## Circuit Balancing

### Circuits Balanced by Manual Valves

Traditionally, circuits are balanced using manual balancing valves.

With manual balancing valves, the circuits are only balanced at full load conditions and any changes within the circuits can affect the balance and flow rate to individual circuits to a greater or lesser degree.

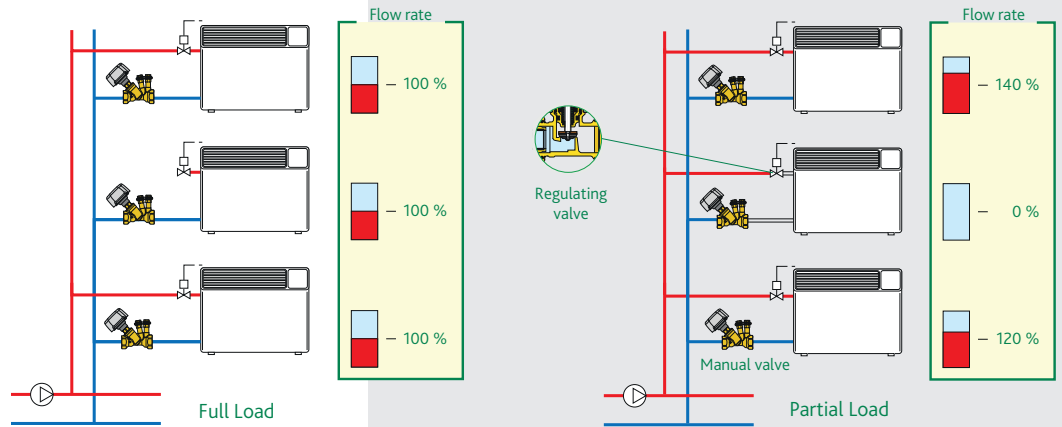

### Circuits Balanced by Automatic Balancing Valves

ABVs balance the circuit automatically, by ensuring each terminal emits the design flow rate.

Even in the case of partial circuit closure by means of the regulating valves, the flow rates in the open circuits remain constant at the designated value.

The system always maintains the greatest comfort and energy savings.

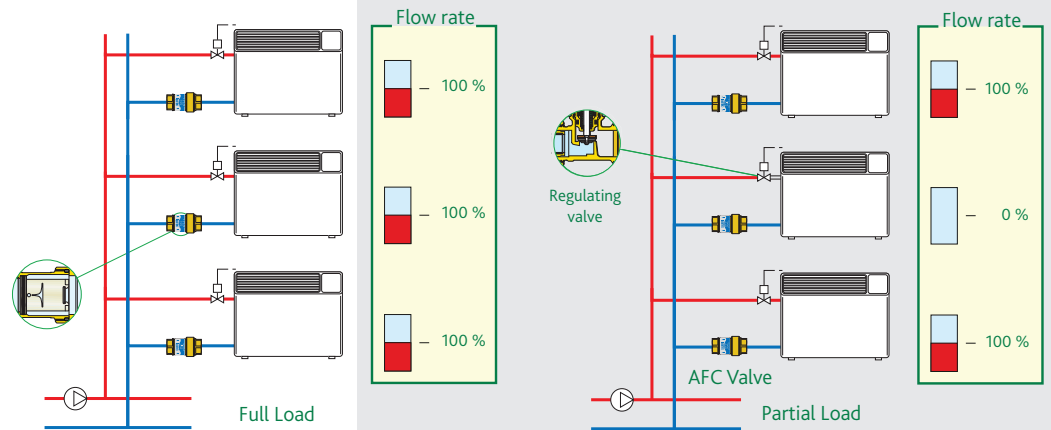

### Sizing the Circuit with Automatic Balancing Valves

Sizing the circuit containing ABVs is particularly easy to accomplish.

As illustrated alongside by the example diagrams, calculation of the loss of head in order to choose the pump is made by referring to the most unfavourable circuit and by adding this value to the minimum differential pressure required by the ABVs.

In the example the circuits have the same nominal flow rate.

The ABV, located on intermediate circuits, automatically absorb the excess differential pressure to ensure the corresponding nominal flow rate.

As the regulating valves open or close, the cartridge repositions itself dynamically to maintain the nominal flow rate (50% load = circuits 3, 5, 7, 8 closed).

For more detailed information on sizing a system with Altecnic Automatic Balancing valves, please refer to the Altecnic Technical Department.

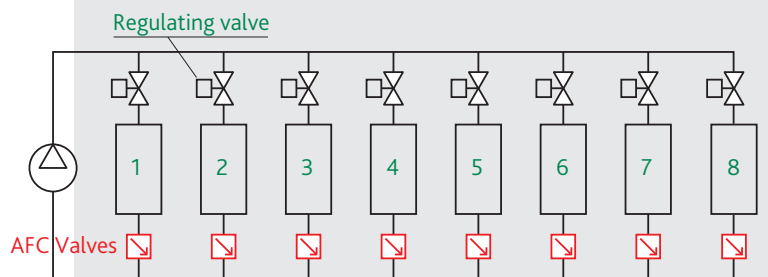

### Differential pressures ( $\Delta p$ )

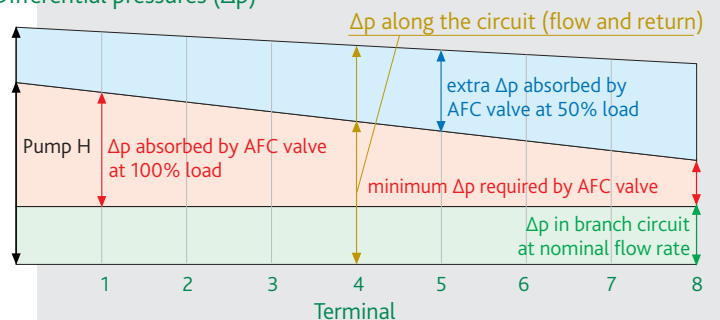

# 127 automatic balancing valve

## Function

The Altecnic automatic balancing valve is intended to maintain a constant flow rate when the upstream differential pressure varies.

It is therefore necessary to refer to the  $\Delta p$  - flow rate diagram and to a basic diagram illustrating the operating methods and the relevant variable effects.

## Operating principle

The regulating element of these devices is composed of a cylinder and a piston with fixed and variable geometry orifices, through which the fluid flows. The surface area of these orifices is governed by the piston movement when pushed by the flow. A specially calibrated spring counteracts this movement.

Altecnic automatic balancing valves are high performance automatic regulators. They regulate selected flow rates within a very tight tolerance (approx. 10%) and offer a wide range of operation.

### Below the Control Range

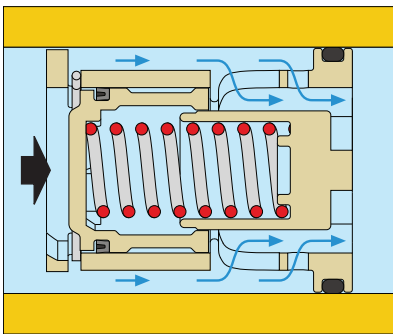

In this case, the regulating piston remains fully out without compressing the spring and gives the maximum free flow area.

In practice, the piston acts as a fixed orifice and thus the flow through the depends solely on the differential pressure.

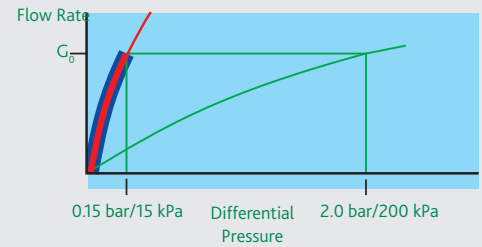
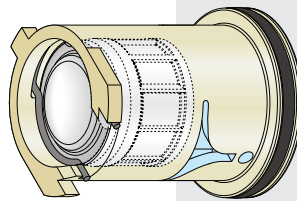

$$Kv_{0,01} = 0.258 \times G_0 \Delta p \text{ range } 15 - 200 \text{ kPa} \text{ where } G_0 = \text{design flow rate}$$

### Within the Control Range

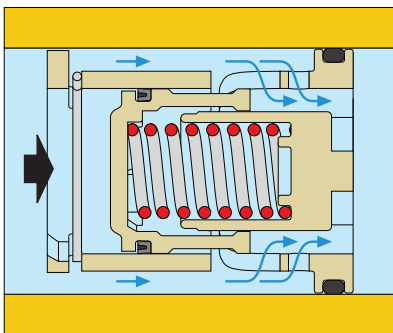

If the differential pressure is within the control range, the piston compresses the spring and gives the medium a free flow area to permit the designated flow to pass.

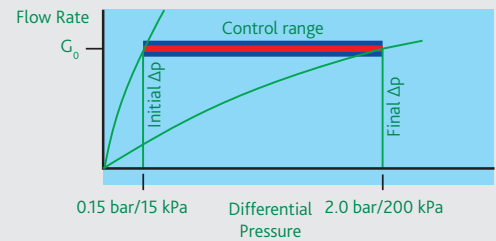
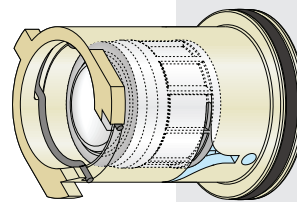

### Above the Control Range

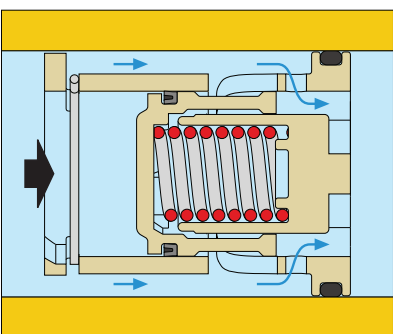

In this case, the piston is fully compressed and only allows flow through the fixed orifice.

The flow rate through the ABV thus depends solely on the differential pressure.

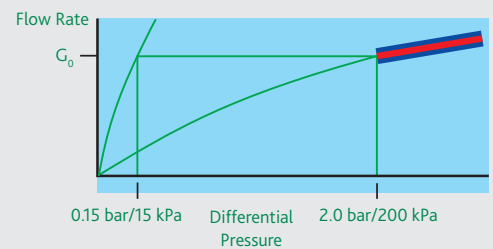
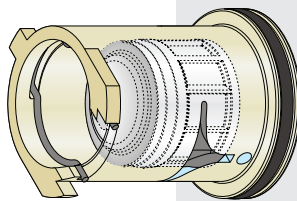

$$Kv_{0,01} = 0.070 \times G_0 \Delta p \text{ range } 115 - 200 \text{ kPa} \text{ where } G_0 = \text{design flow rate}$$

# 127 automatic balancing valve

## Construction Details

### Polymer cartridge

The flow cartridge is made entirely of high resistance polymer, suitable for use in air conditioning and heating systems.

Its mechanical behaviour is excellent over a wide range of temperatures.

It has high resistance to abrasion caused by continuous liquid flow and has good scale resistance.

It is fully compatible with glycols and other additives used in these systems.

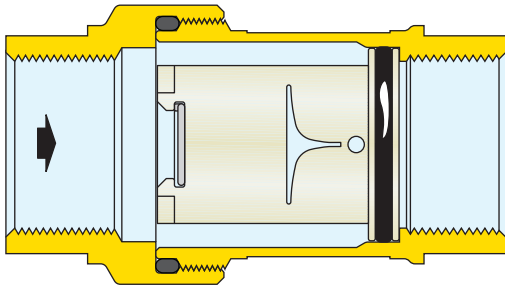

### Flow cartridge

The flow cartridge is able to accurately regulate the flow rate over a wide range system operating pressures.

The internal chamber acts as a damper for vibrations created by the flowing liquid reducing the noise level.

For these reasons it can be used in system circuits both as branch valves and directly at the terminal emitters.

### Replaceable cartridge

The valve must be removed from the pipework for inspection or replacement of the flow cartridge.

The cartridge is removed from the body by unscrewing the locking nut.

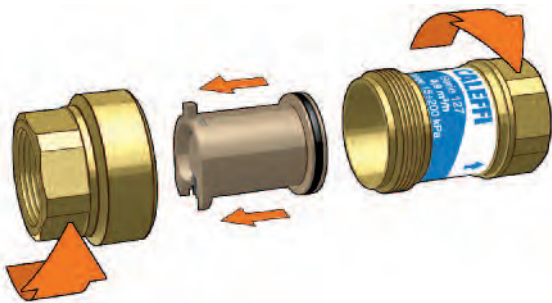

## Typical Application for ABVs

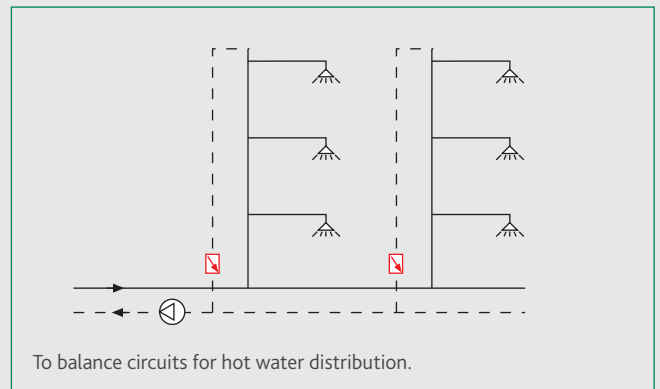
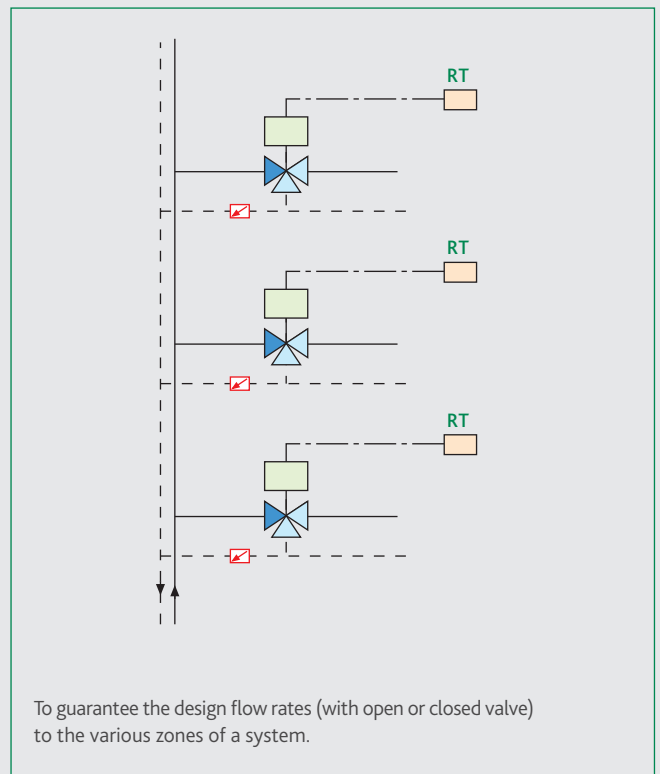
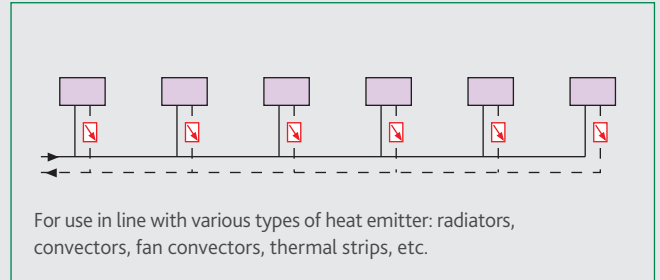

# 127 automatic balancing valve

## Flow Rate Table for 127 Series

Code	Min Working $\Delta p$ (kPa)	$\Delta p$ Range (kPa)	Flow rate (m <sup>3</sup> /h)
127141...	15	15 to 200	0.12, 0.15, 0.2, 0.25, 0.3, 0.35, 0.4, 0.5, 0.6, 0.7, 0.8, 0.9, 1.0, 1.2
127151...	15	15 to 200	0.12, 0.15, 0.2, 0.25, 0.3, 0.35, 0.4, 0.5, 0.6, 0.7, 0.8, 0.9, 1.0, 1.2, 1.4, 1.6

Code	Min Working $\Delta p$ (kPa)	$\Delta p$ Range (kPa)	Flow rate (l/s)
127141...	15	15 to 200	0.033, 0.042, 0.055, 0.25, 0.069, 0.083, 0.11, 0.14, 0.16, 0.19, 0.22, 0.25, 0.27, 0.33
127151...	15	15 to 200	0.033, 0.042, 0.055, 0.25, 0.069, 0.083, 0.11, 0.14, 0.16, 0.19, 0.22, 0.25, 0.27, 0.33, 0.39, 0.44

## Coding for the 127 Automatic Flow Regulator

For correct identification of the 127 regulators including the cartridge the code must be in the following order;

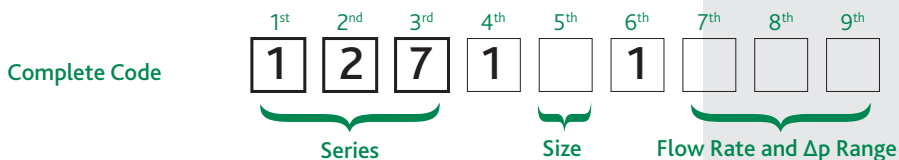

### Size

5<sup>th</sup>

The fifth digit indicate the size

Size	1/2"	3/4"
Digit	4	5

### Flow Rate & $\Delta p$ Range

6<sup>th</sup>

The last three digits indicate the available range of flow rates.  $\Delta p$  range 15 to 200 kPa

Flow Range m <sup>3</sup> /h	Cartridge Code
0.12	M12
0.15	M15
0.20	M20
0.25	M25
0.30	M30
0.35	M35

Flow Range m <sup>3</sup> /h	Cartridge Code
0.4	M40
0.5	M50
0.6	M60
0.7	M70
0.8	M80
0.9	M90

Flow Range m <sup>3</sup> /h	Cartridge Code
1.0	1M0
1.2	1M2
1.4	1M4
1.6	1M6

# 127 automatic balancing valve

Typical Application for ABVs  Continued

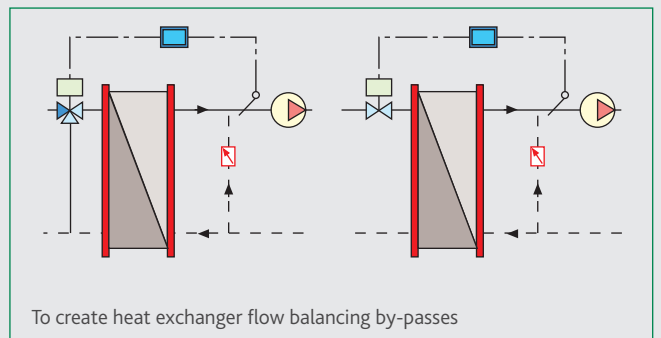
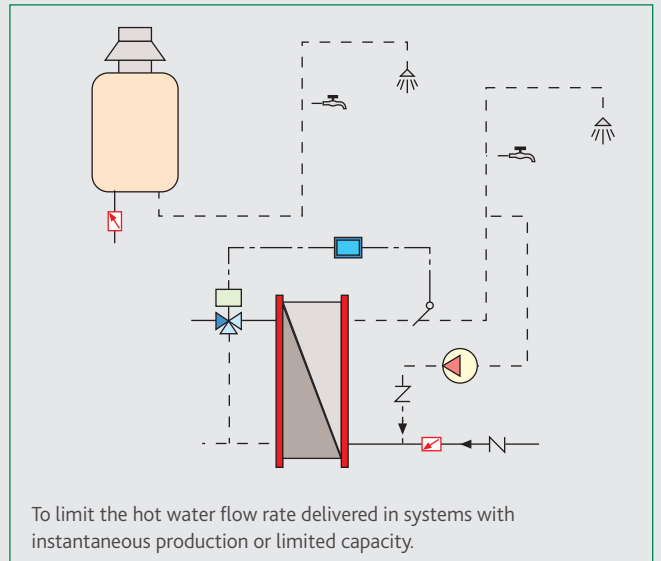
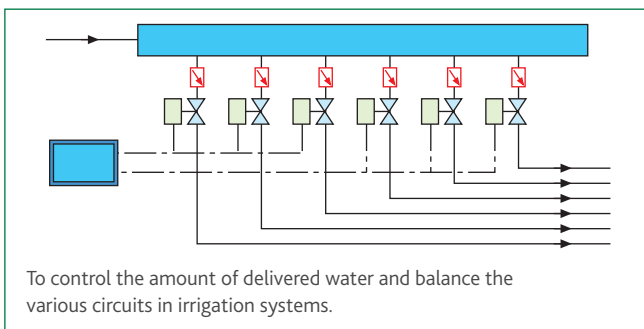
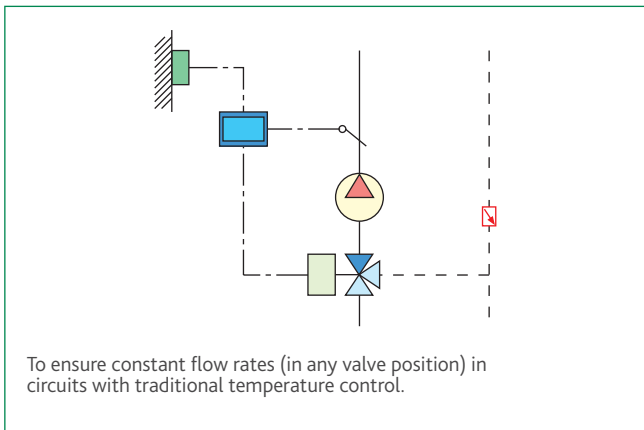
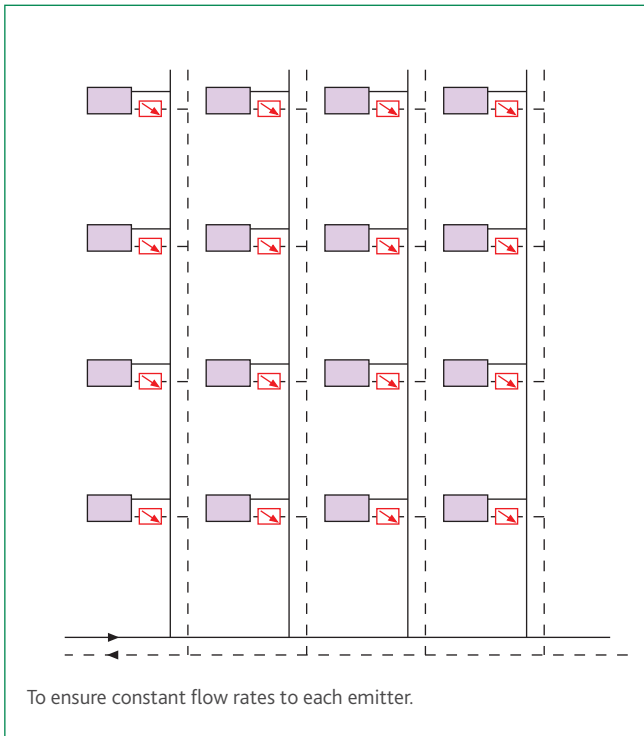

# 127 automatic balancing valve

© Patents & Design Altecnic 2025

Altecnic Ltd retains all rights (including patents, designs and copyrights, trademarks and any other intellectual property rights) in relation to all information provided on or via the website, brochures or any other documents, including all texts, graphics and logos, contained on the website, in brochures or in any other documents published in the name of or on behalf of Altecnic Ltd in any form, without prior written consent of Altecnic Ltd.

Altecnic Ltd Francesco House, Staples Close, Stafford ST16 1WQ

T: +44 (0)1785 218200 E: [sales@altecnic.co.uk](mailto:sales@altecnic.co.uk)

Registered in England No: 02095101

[altecnic.co.uk](http://altecnic.co.uk)

AL 268 20-03-25

E & O.E

© Altecnic Limited. 2025

ALTECNIC™

**altecnic**  
CALEFFI group